

Switching Power Supply Type SPD 240W 3 phases DIN rail mounting

CARLO GAVAZZI



- Universal AC 3 phases input full range
- Installation on DIN rail 7.5 or 15mm
- PFC as standard
- High efficiency up to 90%
- Power ready output
- Parallel connection feature
- Compact dimensions
- UL, cUL listed and TUV/CE

Product Description

The Switching power application where the supplies SPD series are specially designed to be used in all automation and performance are a must.

Ordering Key

SP D 24 240 3

Model _____
 Mounting (D= Din rail) _____
 Output voltage _____
 Output power _____
 Input Type _____

Input type: 3 = three phase

Approvals



Output Performances

MODEL NO.	RATED INPUT VOLTAGE	OUTPUT WATTAGE	OUTPUT VOLTAGE	OUTPUT CURRENT	EFF. (min.)	EFF. (typ.)
Single Output Models						
SPD24	400 - 500VAC	240 WATTS	+24 VDC	10 A	85%	90%
SPD48	400 - 500VAC	240 WATTS	+48 VDC	5 A	89%	91%

Output Data

Line regulation	± 1%	Voltage fall time ($I_{o,nom}$)	150ms max
Load regulation		Rated continuous loading	
Single mode	±1%	24V Model	10A @ 24VDC/8.2A @ 28.5VDC
Parallel mode	±5%	48V Model	5A @ 48VDC/4.2A @ 56VDC
When S/P switch is set to parallel, it is not possible to trim output voltage.		Reverse voltage	
Minimum load	0A	12V Model	35VDC
Turn on time (full resistive load)		24V Model	63VDC
VI nom, Io nom	1000ms	Capacitor load	
VI nom, Io nom 12V model with 7000 µF CAP	1500ms	VI nom Io nom 24V model	7000µF
Transient recovery time	2ms	Voltage rise time	
Ripple and noise	100mVpp	VI nom Io nom	150ms
Output voltage accuracy	±1%	VI nom, Io nom	
Temperature coefficient	±0.03%/°C	12V model with 7000µF CAP	500ms
Hold up time Vi	20ms		

Input Data

Rated input voltage	400 - 500VAC		
Voltage range			
AC	3PH AC IN 340 - 575Vac 47-63Hz		
DC	2PH AC IN 340 - 575Vac 47-63Hz (with 2P the output is derated to 75%) 480 - 820VDC		
Input current (Vi: 400VAC / 500VAC, Io nom)			
Typ.	0.65A / 0.55A		
Rated input current (Vi: 340VAC, Io nom)			
Max.	0.85A		
Inrush current		Typ.	20A
Vi nom, Io nom		Max.	25A
Inrush current time			
Vi nom, Io nom			4 ~ 6 ms
Power dissipation			
24V Model			30W
48V Model			24W
Frequency range			47-63Hz
Leakage current			
Input-Output			0.25mA
Input-FG			3.5mA

Controls and Protections

Input fuse ¹⁾	2A/600VAC internal/Phase		
Output short circuit	Hiccup mode		
Power ready output (only 24V model) on threshold	≥17.6-19.4VDC		
Electrical isolation	500VDC		
Contact rating at 60VDC	0.3A		
Over voltage protection		VDC	
24V Model		Min.	Max.
48V Model		30	33
Internal surge voltage protection (IEC 61000-4-5)		60	68
			Varistor

1) Fuse not replaceable by user

General Data (@ nominal line, full load, 25°C)

Ambient temperature	-40°C to +71°C	MTB (Bellcore issue 6 @ 40°C, GB)	
Derating (>61°C to +71°C)	2.5%/C	24V Model	488000 Hours
Ambient humidity	20 ~ 90% RH	48V Model	519000 Hours
Storage	-25°C to +85°C	Case material	Metal
Protection degree	IP20	Dimensions LxWxD mm(inch)	124 (4.88) x 89 (3.5) x 118.8 (4.68)
Cooling	Free air convection	Weight	1100 g
Pollution degree	2		

Norms and Standards

Vibration resistance	meet IEC 60068-2-6 (Mounting by rail: 10-500Hz, 2G, along X, Y, Z each Axis, 60 min for each Axis)	CCC	Available upon request
Shock resistance	meet IEC 60068-2-27 (15G, 11ms, 3 Axis, 6 faces, 3 times for each face)	CE	EN 61000-6-3, EN 55022 Class B, EN 61000-3-2, EN 61000-3-3, EN 61000-6-2, EN 55024, EN 61000-4-2 Level 4, EN 61000-4-3 Level 3, EN 61000-4-4 Level 4, EN 61000-4-5 Level 3, L/N-FG Level 4, EN 61000-4-6 Level 3, EN 61000-4-8 Level 4, EN 61000-4-11, ENV 50204 Level 2, EN 61204-3
UL/cUL	UL508 listed, UL60950-1, Recognized, ISA 12.12.01 (Class 1, Division 2, Groups A, B, C and D)		
TUV	EN 60950-1, CB scheme EN 61558-1, EN 61558-2- 17 (meet EN 60204)		

Block Diagram

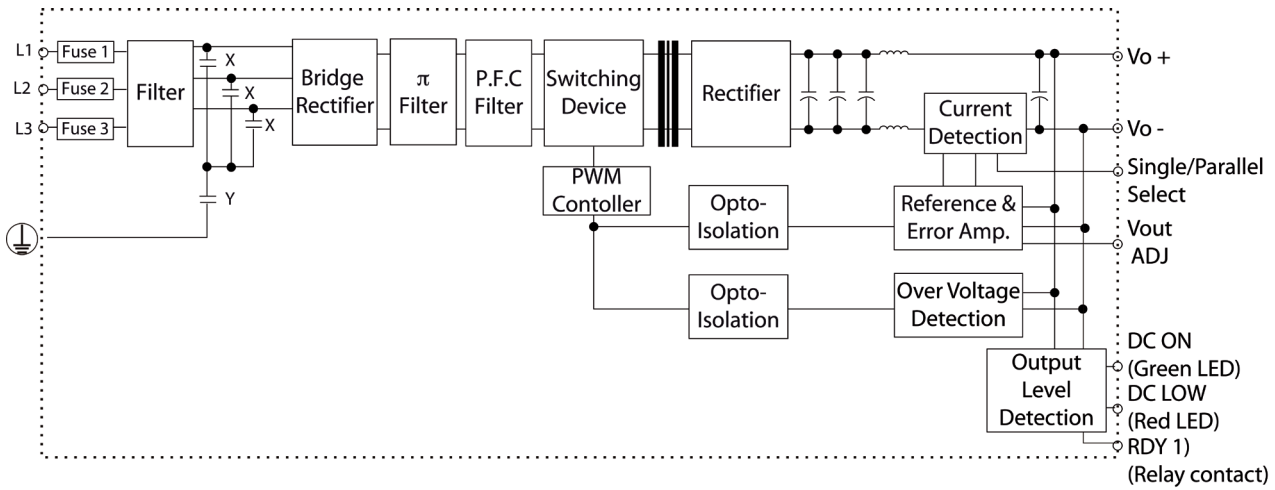

Pin Assignment and Front Controls

Pin No.	Designation	Description
1, 2	V-	Negative output terminal
3, 4	V+	Positive output terminal
5	L3	Input terminals
6	L2	Input terminals
7	L1	Input terminals
8	⊥	Ground this terminal to minimize high-frequency emissions
9	RDY	A normal open relay contact for DC ON level control
10	RDY	(Never connect except 24V model)
	DC ON	Operation indicator LED
	DC LO	DC LOW voltage indicator LED
	Vout ADJ	Trimmer-potentiometer for Vout adjustment
	S/P	Single / Parallel select switch

Derating Diagram

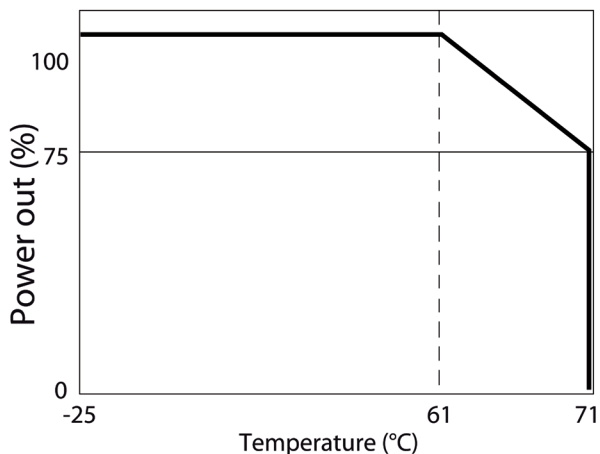

Typ. Efficiency Curve

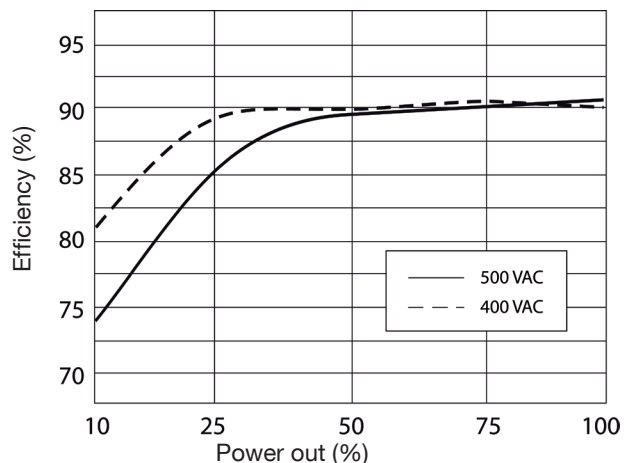

Typ. Current Limited Curve

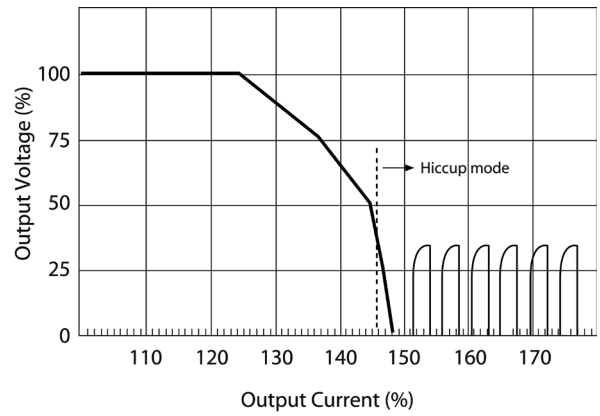
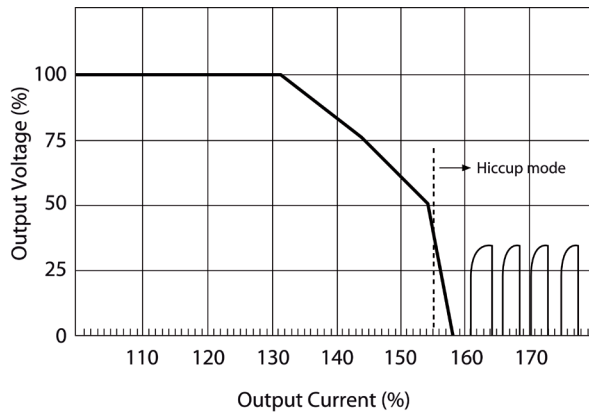

Mechanical Drawings mm (inches)

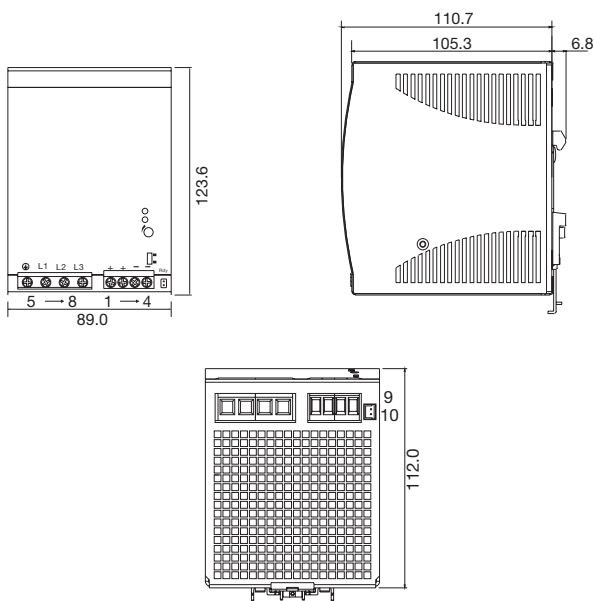

Installation

Ventilation and cooling

Normal convection All sides
 25mm free space for
 cooling is recommended.

Screw connections

10-24AWG flexible or solid
 cable 8mm stripping
 recommend.

Max. torque for screws terminals Input terminal Output terminal

1.008Nm (9.0lb-in)
 0.616Nm (5.5lb-in)