

Dupline® Carpark System Type GP 3496 0005

CARLO GAVAZZI



- Interface for Modbus-RTU with the function of a slave
- Built-in Dupline® Channel Generator
- Dupline® bus and DC power supply on 3 wires
- RS485 port for making an interface to the control system
- Multidropping of up to 16 devices on a RS485 line
- LED-indications for supply, Dupline® carrier and Com-port TX
- Galvanically isolated Com-port supplied by internal DC/DC converter
- Sends out sync. signal for the Carpark sensors
- 512 modules with unique ID can be connected to the Dupline® bus. Each module can handle 120 sensors with unique addresses.
- cULus approved

Product Description

GP 3496 0005 has been designed as a cost-effective Plug & Play solution for making an interface between Dupline® Carpark and the PC with monitory software. It has four functions: Dupline® channel generator, power

supply synchronization (enables a 3-wire system with supply), RS485 interface, and it produces a synchronization signal on four specific Dupline® addresses for the Dupline® Carpark system.

Ordering Key

GP34960005700

Type: Dupline® _____
H4-Housing _____
Combined module _____
Interface type _____
DC supply _____

Type Selection

Supply	Modbus Conformance	Ordering no.
20-30 VDC	Modbus-RTU, Function code 01, 02, 03, 04, 05, 06 & 16	GP 3496 0005 700

Input/Output Specifications

Power output	
Output voltage	20-30 VDC (pulsating)
Output current	< 3.0 A @ 50°C
Short circuit protection	4 A quick acting fuse
Output voltage drop	< 1.0 V
Dupline® carrier	
Output voltage	8.2 V (pulsating)
Current	< 60 mA
Short circuit protection	Yes
Scan time	
128 channels	132.2 ms
64 channels	69.8 ms
Communication port	
Standard	RS 485
Split I/O / Normal mode	Normal mode
Connection	9 pole female SUB-D
Dielectric voltage	
Com-port - Dupline®	1 kVAC (rms)
Protocol	Modbus-RTU
Baudrate	9600
Data bits	8
Start bit	-
Stop bit	1
Parity	None
Flow-control	None
Pin assignment	
2-wire RS 485	
S/R Data line + (B)	Pin 3
S/R Data line - (A)	Pin 8
GND	Pin 5

General Specifications

Power ON delay	2 s
Indication for	
Com-port Tx	LED, red
Supply ON	LED, green
Dupline® carrier	LED, yellow
Environment	
Pollution degree	3 (IEC 60664)
Operating temperature	-40° to +50°C (-40° to +122°F)
Storage temperature	-50° to +85°C (-58° to +185°F)
Humidity (non-condensing)	20 to 80%
Mechanical resistance	
Shock	15 G (11 ms)
Vibration	2 G (6 to 55 Hz)
Dimensions	H4-Housing
Material	PC/ABS CYCOLOY C 2100
Weight	100 g
Approval	cULus (UL60950)
MTBF	65,000 hours



Supply Specifications

Power supply	Overvoltage cat. III (IEC 60664)
Operational voltage (V _{in})	20-30 VDC
Reverse polarity protection	None
Current consumption	< 150 mA + Power load
Power dissipation	< 5 W
Transient protection voltage	800 V
Dielectric voltage	
Supply - Dupline®	None
Supply - com-port	1 kVAC (rms)

Mode of Operation

The Dupline® Master Module (DMM) is a Dupline® channel generator with the function of a slave. This means that the 120 Dupline® I/O's can be read/controlled by a PC/PLC or a control board master from many different

Mode of Operation

suppliers. Up to 64 Dupline® master modules (DMMs) can be connected to the same network. The GP34960005 has been developed for carpark installations. The address area P1 - P8 is reserved for internal use and cannot be used for programming sensors etc. P1 is dedicated for calibration. P5, P6, P7 and P8 is dedicated for the synchronization signal. This synchronization signal ensures that two neighbour sensors are not making ultrasonic measurements simul-

taneously. The GP34960005 has 6 dip switches on the front which give the user up to 64 device numbers to select. That is 64 x 120 = 7680 sensors in an entire system.

However, the GP34960005 has 3 additional jumpers inside the module, so it is possible to increase the total amount to 512 device numbers. That is 512 x 120 = 61440 sensors. (Please contact Carlo Gavazzi if you need this option.)

Dip-Switch Settings

Sw. 1 - 6 On/Off: Device no. 1 - 64

Device no.	MSB		LSB			
	Sw1	Sw2	Sw3	Sw4	Sw5	Sw6
01	0	0	0	0	0	1
02	0	0	0	0	1	0
03	0	0	0	0	1	1
04	0	0	0	1	0	0
-						
63	1	1	1	1	1	1
64	0	0	0	0	0	0

The DMM acts as an interface between the RS485 network and the Dupline network. Any DMM is identified by a master address and a modbus device address that contains different values (see below). The rules of the system are the following:

1. It is not allowed to put two GP3496's with the same modbus device address on the same MOXA
2. It is not allowed to have two GP3496's in the entire system with the same master address.

Master address

This address is selected by using ALL 6 DIP-switches in the front of the module and the J2, J3, J4 (referred to as "jumpers") mounted on the PCB. The master address is read as:

- Bit 15-9= 0
- Bit 8 = 1 - if jumper2 is removed
- Bit 7 = 1 - if jumper3 is removed
- Bit 6 = 1 - if jumper4 is removed
- Bit 5 = 1 - if dipswitch1 is ON
- Bit 4 = 1 - if dipswitch2 is ON
- Bit 3 = 1 - if dipswitch3 is ON
- Bit 2 = 1 - if dipswitch4 is ON
- Bit 1 = 1 - if dipswitch5 is ON
- Bit 0 = 1 - if dipswitch6 is ON

Using the J2 as MSB ensures that the jumpers have the same MSB-LSB direction as the DIP-SW.

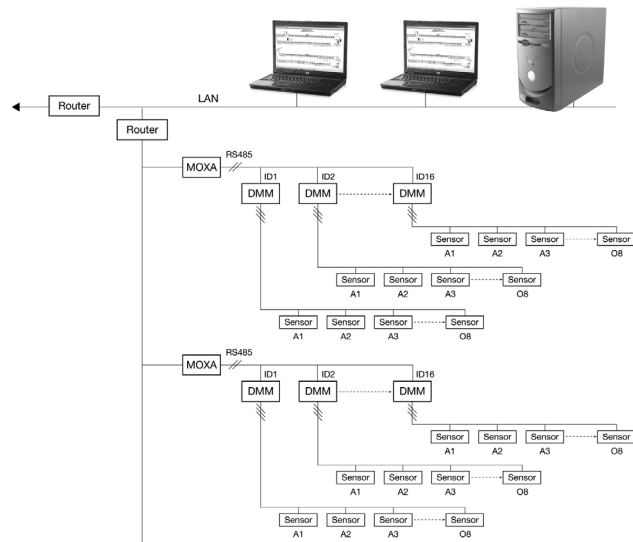

The master address "0" is allowed. Therefore, when all DIP-SW are in "0" position it shall be read as master address "0". The jumpers are mounted on the PCB by default, so the bits 6-8 are generally read as 0.

Modbus device address

Please note that the master address and the modbus device address are two different things here. The modbus device address is read from the 4 dipswitches SW3-SW6, so practically it uses only the 4 LSBs of the master address. However, the modbus device address 0 is not allowed.

- When the 4 DIP-switches (sw3-sw6) are in "0000" position, it must be interpreted by the GP3496 as modbus address 16, so the GP3496 must answer telegrams sent to device 16, and reply using modbus address = 16
- This means: valid modbus device addresses are in the range 1-16.

Telegram Structure

Modbus-RTU Function code 01: Read Output Table (Data to receivers) or 02: Read Input Table (Data from transmitters)

Field Name	Example (HEX)	Description
Slave Address	07	Addressed to DMM no. 7
Function	01/02	Read Output/Input Table
Starting Point no. Hi	00	Read Dupline® A6
Starting Point no. Lo	05*	(Point no. 6)
Number of points	00	Always 00 01
Number of points	01	
Error Check	XX XX	-

Response Message

Field Name	Example (HEX)	Description
Slave Address	07	Addressed from DMM no. 7
Function	01/02	Read Output/Input Table
Byte Count	01	1 byte
Data	01	Dupline® Channel A6 (ON)
Error Check	XX XX	-

Modbus-RTU Function Code 03: Read Holding Registers Query message

Field Name	Example (HEX)	Description
Slave Address	07	Addressed to DMM no. 7
Function	03	Read Registers
Starting Address Hi	00	Starting register no. 0
Starting Address Lo	00*	
Number of registers Hi	00	Read 5 Registers (Group A-J)
Number of registers Lo	05	
Error Check	XX XX	-

Response Message

Field Name	Example (HEX)	Description
Slave Address	07	Addressed from DMM no. 7
Function	03	Read Registers
Byte Count	0A	10 bytes (5 Registers)
Data Hi Register no. 1	00	Dupline® Group B
Data Lo Register no. 1	40	Dupline® Group A (A7 ON)

Data Hi Register no. 5	00	Dupline® Group J
Data Lo Register no. 5	00	Dupline® Group I
Error Check	XX XX	-

Modbus-RTU Function Code 16: Write Multiple Registers Query Message

Field Name	Example (HEX)	Description
Slave Address	07	Addressed to DMM no. 7
Function	10	Write Registers
Starting Address Hi	00	Starting Register no. 0
Starting Address Lo	00*	
Number of registers Hi	00	Write 5 Registers (Group A-J)
Number of registers Lo	05	
Byte Count	0A	10 bytes (5 Registers)
Data Hi Register 1	02	Dupline® Group B (B2 ON)
Data Lo Register 1	00	Dupline® Group A

Data Hi Register 5	00	Dupline® Group J
Data Lo Register 5	00	Dupline® Group I
Error Check	XX XX	-

Response Message

Field Name	Example (HEX)	Description
Slave Address	07	Addressed from DMM no. 7
Function	10	Write Registers
Starting Address Hi	00	Starting register no. 0
Starting Address Lo	00*	
Number of registers Hi	00	Write 5 Registers (Group A-J)
Number of registers Lo	05	
Error Check	XX XX	-

* According to modbus protocol definition the starting address/point is transferred as one less than the number of the first reg/point to be read/written to

Memory Mapping

Read Output Table (01). Read Input Table (02) and Force Single Output (05)

Point no.	Dupline® Channel
1	A1
2	A2
3	A3
-	-
120	O8

Digital read (Modbus Function 03) and Digital Write (Modbus Function 16)

Reg. no.	HIGH BYTE								LOW BYTE							
	MSB							LSB	MSB							LSB
1	B8	B7	B6	B5	B4	B3	B2	B1	A8	A7	A6	A5	A4	A3	A2	A1
2	D8	D7	D6	D5	D4	D3	D2	D1	C8	C7	C6	C5	C4	C3	C2	C1
3	F8	F7	F6	F5	F4	F3	F2	F1	E8	E7	E6	E5	E4	E3	E2	E1
4	H8	H7	H6	H5	H4	H3	H2	H1	G8	G7	G6	G5	G4	G3	G2	G1
5	J8	J7	J6	J5	J4	J3	J2	J1	I8	I7	I6	I5	I4	I3	I2	I1
6	L8	L7	L6	L5	L4	L3	L2	L1	K8	K7	K6	K5	K4	K3	K2	K1
7	N8	N7	N6	N5	N4	N3	N2	N1	M8	M7	M6	M5	M4	M3	M2	M1
8	P8	P7	P6	P5	P4	P3	P2	P1	O8	O7	O6	O5	O4	O3	O2	O1
129									A1	A2	A3	A4	A5	A6	A7	A8
130									B1	B2	B3	B4	B5	B6	B7	B8
131									C1	C2	C3	C4	C5	C6	C7	C8
132									D1	D2	D3	D4	D5	D6	D7	D8
-									-	-	-	-	-	-	-	-
144									P1	P2	P3	P4	P5	P6	P7	P8

Wiring Diagrams

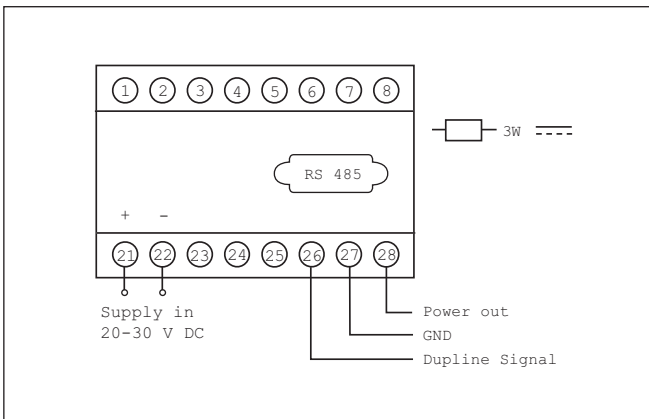

Dimensions (mm)

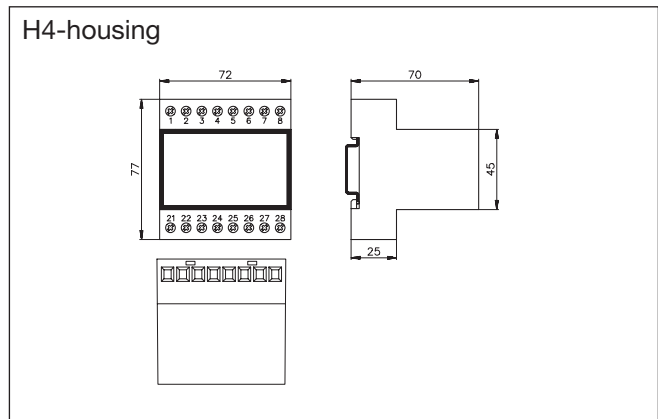

Installation Hints

No TX-LED

Checksum Error

The Checksum has been calculated in a wrong way.

Wrong telegram structure

See "Telegram Structure"

Hardware fault

Check the wiring. Try to send the telegram-example Structure.

No Dupline® Carrier-Led

Short circuit

Short circuit between the two Dupline® wires.

Additional Information

Modbus RTU memory map and Modbus RTU telegram structure can be downloaded from our homepage www.dupline.com. Choose "download" and then "product specific".

Delivery Contents

1 x Master Module

GP3496 0005 700