

ZCT(Zero-phase Sequence Current Transformer)

Ratings

Type	Diameter(A)	Ratio	Weight(kg)	Model
CGD-ZCT30	30	200mA/100mV	0.5	LZT-030
CGD-ZCT50	50		0.7	LZT-050
CGD-ZCT65	65		0.9	LZT-065
CGD-ZCT80	80		1.5	LZT-080

Dimension

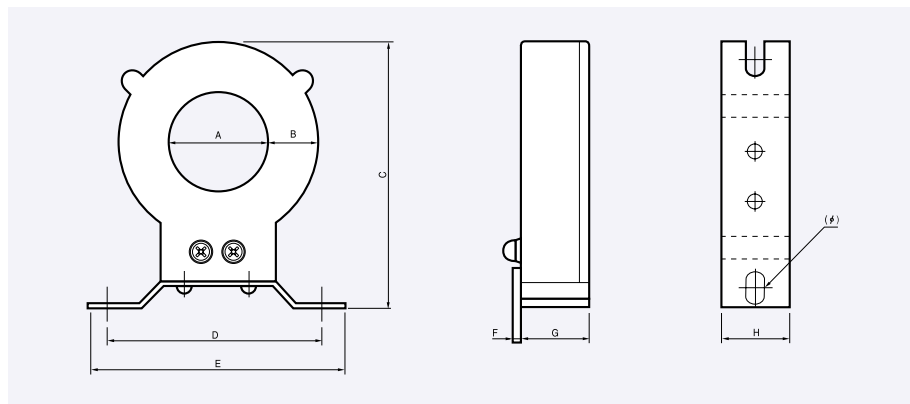

Unit : m/m

Model	A	B	C	D	E	F	G	H	φ
LZT-030	30	25	108	100	114	7	32	32	6
LZT-050	50	25	131	100	122	7	32	36	6
LZT-065	65	26	143	114	133	7	39	37	6