

Multi-range μ P-based
Panel Rate Meter and Controller
Indicatore/Controllore multifunzione
a μ -processore per misure di
frequenza e velocità



MDM 40 TF / MDI 40 TF



Instruction Manual
Manuale Istruzioni

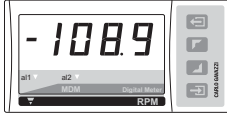

MDI40.TF Rate meter and controller

OPERATING INSTRUCTIONS

• General Features	2
• Technical Features	3
• Installation	7
• Preliminary Operations	12
• Front Panel Description	13
• Operating mode	15

Important:

We suggest you keep the original packing for a further shipping of the instrument.

In order to guarantee a correct use of the instrument, we recommend the user to carefully read the present instruction manual.

CARLO GAVAZZI Instruments
Multi-range μ P-based panel rate meter

MDI40.TF

rev. 0

OPERATING INSTRUCTIONS

Important:

We suggest you keep the original packing for a further shipping of the instrument.

In order to guarantee a correct use of the instrument, we recommend the user to carefully read the present instruction manual.

GENERAL FEATURES

Features:

- display of measured value;
- two independent control points;
- scaling capability;
- transmission of measured value.

Programming parameters:

- password;
- three levels of password protection;
- range: 500 Hz or 50 KHz;
- time base;

- operating mode;
- scaling;
- display;
- commands;
- alarm set-points;
- filter;
- analogue output;
- serial output.

TECHNICAL FEATURES

ACCURACY ± 0.01 % F.S., ± 3 dgt (@ 18°C to 23°C);

RESPONSE TIME Time base + ≤ 200 msec.

TEMPERATURE DRIFT ± 100 ppm/°C.

DISPLAY 7-segment, red LED, h 14.2 mm.

MAXIMUM INDICATIONS 9999.

MINIMUM INDICATIONS -1999.

INPUTS 2 measuring inputs (channel "A" and channel "B"); 2 ranges:
 range r1: 0.001 to 500Hz; minimum duration of ON signal 500 μ sec;
 period measurement: 2ms to 1000s;
 range r2: 0.1 to 50KHz, minimum duration of ON signal 9 μ sec;
 period measurement: 20 μ s to 10s;

INPUT TYPE

DC: NPN (pins 6 to 7):

ON<2VDC; OFF - Open collector, leakage current ≤ 1 mA.

DC: PNP (pins 6 to 7):

ON>10VDC; OFF - Open collector, leakage current ≤ 1 mA.

DC: NAMUR: ON \leq 1mADC; OFF \geq 2.2 mADC

DC: TTL (pins 6 to 4): ON $>$ 4VDC; OFF \leq 2VDC.

DC: Free of voltage contact: ON $<$ 1K Ω ; OFF $>$ 20K Ω .

AC: PICK-UP voltage up to 100VAC: ON $>$ 2VAC; OFF $<$ 1VAC.

AC: PICK-UP voltage up to 500VAC: ON $>$ 9VAC; OFF $<$ 6VAC.

KEYPAD

4 keys for programming and displaying; "S" for menu selection; "UP" and "DOWN" for value programming/function selection; "F" for special functions and "esc" (escape).

PASSWORD

From 0 to 255, numeric code of max. 3 digits, 3 protection levels of the programming data.

FUNCTIONS

- Frequency measurement of both channels A and B.
- Other functions: Fa-Fb, Fa/Fb, [(Fa-Fb)/Fb]*100, [Fb/(Fa+Fb)]*100, 1/Fa, Fa (Fb for rotation sensing).
- Peak and valley.

ALARM

Type: OFF: out of range alarm; UP: up alarm; DO: down alarm; D.DO: down alarm with disabling at power-on; UP.L: up alarm with latch; DO.L: down alarm with latch.

Set point adjustment: in the whole range of visualization.

Hysteresis: in the whole range of visualization.

Set-point limit adjustment: programmable minimum and maximum limits.

Activation time delay: from 0 to 255s

De-activation time delay: from 0 to 255s

Relay status: programmable normally energized / de-energized.

Output type: 2 contacts SPST, NO, 5A/250VAC/VDC 40W/1200VA, 130.000 cycles.

Min. response time: $<$ 400 msec. filter excluded.

Insulation: see table 1.

DIGITAL FILTER

Operating range: 0 to 9999. Filtering coefficient: from 1 to 255.

ANALOGUE OUTPUT (ON REQUEST)

From 0 to 20mADC / from 0 to 10VDC, programmable within the whole analogue output range. Accuracy: \pm 0.3% F.S. (@ 18°C to 23°C). Response time: 500ms (filter excluded). Temperature drift: \pm 200 ppm/°C. Load: \leq 500 Ω (mA output): \geq 10k Ω (V output). Insulation: see table 1.

SERIAL TRANSMISSION RS485 (ON REQUEST)

Multidrop: uni-directional (STD); bi-directional (on request); 2 or 4 wires; max. distance 1200m; termination and/or line biasing directly on the instrument; 255 programmable addresses; data format: 1 start bit, 8 data bits, no parity, 1 stop bit; baud rate: 1200, 2400, 4800 and 9600 bauds selectable by key-pad; communication protocol according to the standard MODBUS, JBUS.

Uni-directional communication:

dynamic data (reading only): measurement, valley data, peak data, alarm status;

Static data (reading): all programming data;

Bi-directional communication:

dynamic data (reading only): measurement, valley data, peak data, alarm status;

Static data (reading/writing): all programming data, reset of peak and valley data, reset of alarm set-points with latch.

EXCITATION OUTPUT (ON REQUEST)

15VDC / 40mA (12VDC / 60mA) (non-stabilized)

POWER SUPPLY INPUT

230VAC -15% +10% 50/60Hz (standard) (200mAT protection fuse*);

115 VAC -15% +10% 50/60Hz (on request) (200mAT protection fuse*);

48 VAC -15% +10% 50/60 Hz (on request) (630mAT protection fuse*);

24 VAC -15% +10% 50/60 Hz (on request) (630mAT protection fuse*);

120VAC-15% +10% 50/60 Hz (on request) (200mAT protection fuse*);

240VAC-15% +10% 50/60 Hz (on request) (200mAT protection fuse*);

9 to 32VDC galvanic insulation (1AT protection fuse*);

40 to 155VDC galvanic insulation (315mAT protection fuse*).

⚠ *note: the mains has to be protected by means of a proper fuse type

SELF CONSUMPTION

8VA

OPERATING TEMPERATURE

From 0 to +50°C (R.H. <90% non-condensing).

STORAGE TEMPERATURE

From -10 to +60°C (R.H. <90% non-condensing).

INSULATION REFERENCE VOLTAGE

300VRMS

INSTALLATION CATEGORY CAT III - 300V (EN61010-1).

DIELECTRIC STRENGTH 4000 VRMS for 1 minute.

EMC IEC 801-2, IEC 801-3, IEC 801-4 (level 3).

SAFETY STANDARDS EN 61010-1, IEC 1010-1, VDE 0411.

CONNECTIONS screw-type, detachable.

HOUSING SIZE / DIMENSIONS / MATERIAL

1/8 DIN / 48 x 96 x 124 mm / ABS, self-extinguishing: UL 94 V-0.

PROTECTION DEGREE / WEIGHT

IP 65 (standard), 470 g. approximately (included analogue output and packing)

	AC Power Supply	Input	RL1 Output	RL2 Output	Analogue Output	DC Power Supply	Serial Output
AC Power Supply	—	4kV	4kV	4kV	4kV	—	4kV
Input	4kV	—	2kV	2kV	500V	2kV	500V
RL1 Output	4kV	2kV	—	2kV	2kV	2kV	2kV
RL2 Output	4kV	2kV	2kV	—	2kV	2kV	2kV
Anal. Output	4kV	500V	2kV	2kV	—	2kV	500V
DC Power S.	—	2kV	2kV	2kV	2kV	—	2kV
Serial Output	4kV	500V	2kV	2kV	500V	2kV	—

Tab.1: insulation table

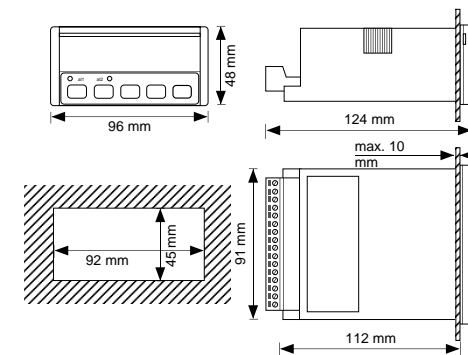
INSTALLATION**Overall dimensions and panel cut-out**

Mounting

Insert the instrument into the panel and fasten it by fixing the two lateral brackets (1) supplied with the instrument to the appropriate location (2), and subsequently locking them by means of the 2 screws (3) supplied with the instrument.

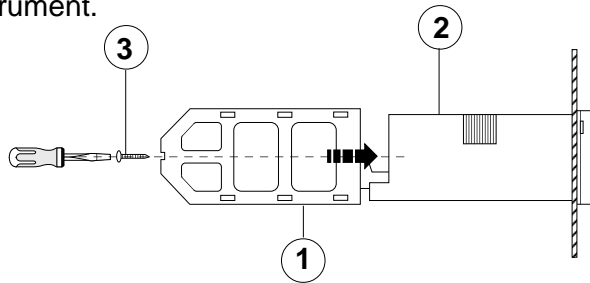

Connections



According to the requirements of EN61010-1 the power supply input of the instrument to be connected to the mains must be protected against short circuit by means of appropriate fuses (see "power supply input").

General connection label for MDI40.TF1

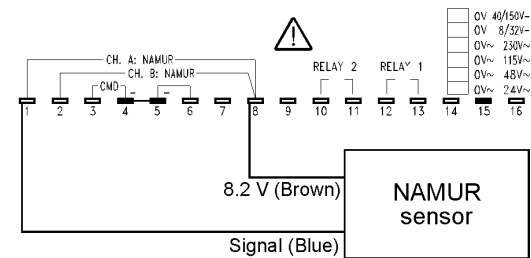
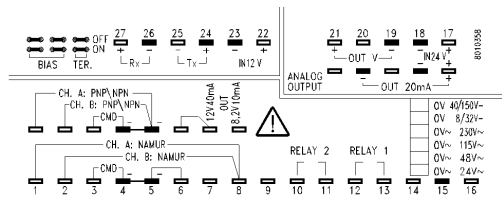

Signal from a 2-wire inductive proximity sensor (NAMUR). NOTE: When using a NAMUR input, the terminals 5 and 6 must be jumpered.

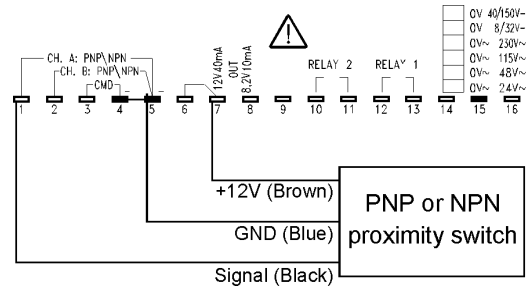

Signal from capacitive or inductive switches, type NPN or PNP, 3 wires. NOTE: when using a NPN or PNP input, the terminals 6 and 7 must be jumpered.

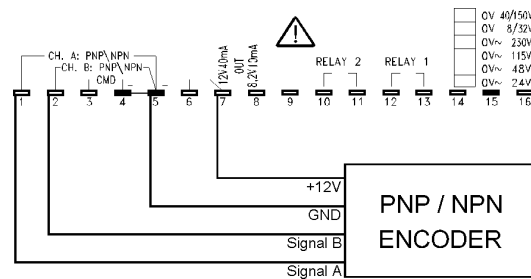

Signal from a PNP/NPN encoder

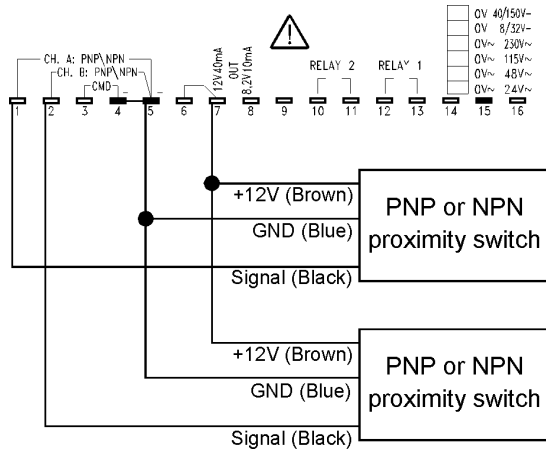

Double input signal from 2 capacitive or inductive switches, type NPN or PNP, 3 wires.
NOTE: when using a NPN or PNP input, the terminals 6 and 7 must be jumpered.

General connection label for MDI40.TF2

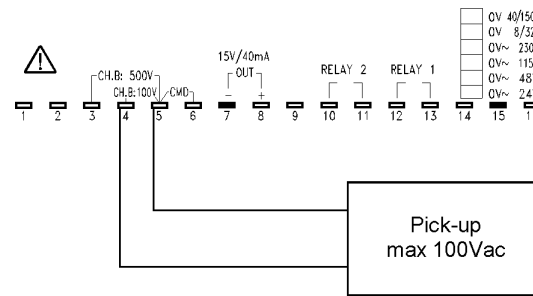
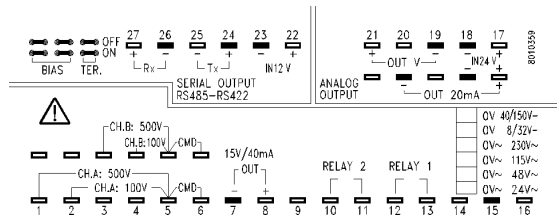

AC signals from pick-up up to 100VAC

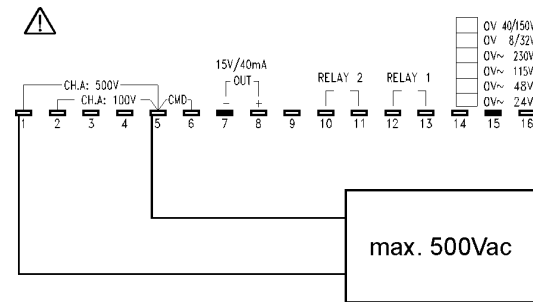

AC signals up to 500VAC

The command input (display hold function or key-pad disabling) must be connected across the terminals 3 and 4 (only free of voltage contact).

The voltage signals must be connected as follows:

- 500V, channel A to the terminals 1 and 5, channel B to the terminals 3 and 5.
- 100V, channel A to the terminals 2 and 5, channel B to the terminals 4 and 5.

Note: when using only input channel A, connect the unused B channel terminals 3 and 4 to the terminal 5

The command input (display hold function or key-pad disabling) must be connected across the terminals 5 and 6 (only free of voltage contact).

PRELIMINARY OPERATIONS

Before supplying the instrument, make sure that the power supply voltage correspond to what is shown on the label. Example:

MDI40.TF1.D.2.A.XX.IX

SER.N. 990600/20078
POWER 230 VAC 50/60 Hz
INPUT NPN, PNP
N. 2 control set points
OUTPUT 0/20 mA - 0/10 VDC

FRONT PANEL DESCRIPTION

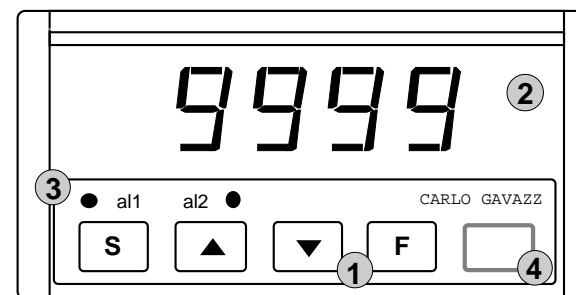

1. Key-pad:

functions available outside the programming phase.

Keys to be pressed:

- Displays set-point 1 corresponding to a password between 0 and 255;
- Displays set-point 2 corresponding to a password between 0 and 255;
- For longer than 2 seconds: modification of set-point 1 (password between 128 and 255 only);
- For longer than 2 seconds: modification of set-point 2 (password between 128 and 255 only);

- + Displays highest measured value (peak function);
- + Displays lowest measured values (valley function);
- For longer than 2 seconds: acknowledge of an alarm (if the relays have the latch function)

1. Key-pad:

functions available in the programming phase.

Keys to be pressed:

For longer than 2 seconds: programming phase entry and password confirmation;

Menu selection (from the first to the last);

Menu selection (from the last to the first);

Confirmation and entry:

- in the configuration menus;
- in the secondary menus relating to parameters.

In the selected menu / secondary menu:

- increase of displayed value
- modification of parameter selection;

In the selected menu/secondary menu:

- decrease of displayed value
- modification of parameter selection;

In the menus: exit from the programming phase (message "End" on the display) and return to the measuring and control function;
In the secondary menus: exit and return to the main menu (the

modification of the selection or programming will not be saved if the
 key has not been previously pressed)

2. Display

Alphanumeric indication by means of a 7-segment display:

- of the measured value;
- of the programming parameters;
- of the measuring abnormal conditions.

3. LED

Indication of the alarm set-point status.

4. Engineering unit window

To insert the interchangeable engineering unit in the special window, proceed as follows: remove the front cover by inserting a suitable screw driver in the special slot on the short sides of the front panel; force gently until the front cover is completely removed. Insert the desired engineering unit by means of a pair of tweezers. Replace the front cover by inserting it first in the lower part and then in the upper part of the locking system.

OPERATING MODE

• Power-on

When you switch the unit on, the display shows for approximately 5 seconds the instruments' software revision, for example: **r.0**.

• Displaying, control and diagnostics

The instrument shows continuously the value of the input variable as defined in the programming phase.

The value shown on the display is continuously compared with the value of the two set-points and of the other parameters, thus generating the control function by energizing/de-energizing the output relays.

• Programming

This phase is identified by the blinking of the decimal point on the right side of the display.

To enter the programming phase, press the "S" key until "PAS" is shown on the display; then "0" is displayed: the correct numerical code (Password) is to be entered. The following conditions may occur:

- **1)** the operator hasn't entered any Password: press the "S" key again to enter the configuration menus of the instrument;
- **2)** the operator has already entered a Password: select the correct Password by means of the "▲" key (to increase the value) or "▼" key (to decrease it) until the desired value is displayed. Press the "S" key to confirm the value: if the Password is correct, then the display will show "PAS" again followed by the relating numerical code; press the "S" key once more in order to display the first configuration menu; if the Password is not correct, the display shows "End" and the instrument goes back to the measuring and control phase.

PROGRAMMING OF A NEW PASSWORD AND AUTOMATIC SELECTION OF THE PROTECTION LEVEL OF THE CONFIGURATION DATA.

To enter the new Password:

- if the Password is "0", press the "S" key when the display shows the

"PAS" message for the second time; enter the desired numerical code using the "▲" or "▼" keys, then confirm it by pressing the "S" key: the display will show the first configuration menu ("InP");

- if the Password has already been entered, you can modify it following the procedure described at No. 2); after the "PAS" message has been shown a second time, enter the new numerical code using the "▲" or "▼" keys and confirm it by pressing the "S" key: the display will show the first configuration menu ("InP").

Data protection levels:

- if the Password is "0", the configuration data are not protected by undesired access;
- if the Password is a number between "1 and 127", the configuration data are entirely protected against undesired access;
- if the Password is a number between "128 and 255", the configuration data are protected against undesired access except for the programming of the values ("SEt") of set-point 1 and/or 2.

It is possible to reset the Password by entering the number 3584.

- **All programming/configuration steps of the instrument are shown in the flow chart on the last page of this manual. The flow chart gives the operator a better understanding of the programming structure of the instrument, indicating the current function with regard to the others. The flow chart also makes it easier to understand the commands used in the programming phase.**

See the chapter "Front panel description" for information regarding the use of the key-pad and the relevant main functions.

Glossary of displayed symbol:

- **PAS** : protection key: programmable from 0 to 255.
- **InP** : input range selection menu:
 - r1** : from 0.001 to 500 Hz or from 2ms to 1000s;
 - r2** : from 0.1 to 50 KHz or from 20µs to 10s
- **t.ba** : time base programming menu: values programmable from 0.1 to 999.9; it is the updating time of both measurement and display.
- **oPr** : operating mode selection menu:
 - General information:
 - "A" means always channel A input;
 - "B" means always channel B input;
 - the signal on the channel A is managed always according to this formula: $(F_a/Pu.1)*PS.1$; the signal on the channel B is managed always according to this formula: $(F_b/Pu.2)*PS.2$. Where: F_a or F_b is the frequency signal measured on channel A or B; $Pu.1$ or $Pu.2$ is the number of pulses per revolution generated by the sensor connected to channel A or B; $PS.1$ or $PS.2$ is the prescaler value of the sensor A or B.

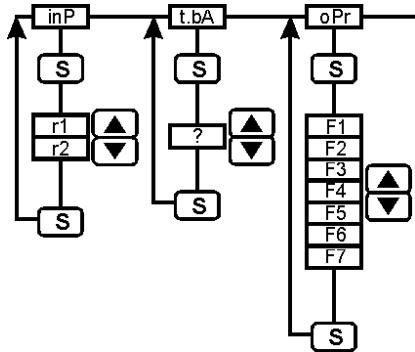

F1 : frequency, tachometer, rate mode A or B channel

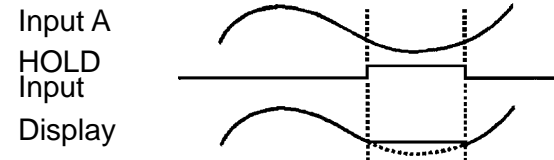

The instrument measures the frequency either on input A or on input B and executes the following calculation: $display = F_a/Pu.1*PS.1$ (or $F_b/Pu.2*PS.2$). It can be used, for example, to measure the rotation speed of a motor, or to display frequency in Hz and kHz, as tachometer mode: RPS, RPM, RPH, MPS, MPM, MPH and as rate meter: flow (m^3 , cm^3 , mm^3 , kg/m^3 , g/cm^3 , l/s , l/min , l/h , m^3/s , m^3/min , m^3/h , t/h , kg/s) or speed (mm/s , cm/s , m/s , mm/min , cm/min , m/min , mm/h , cm/h , m/h , km/h , in/s , ft/s , yd/s , in/min , ft/min , yd/min , in/h , ft/h , yd/h).

F2 : A - B, frequency (speed) difference

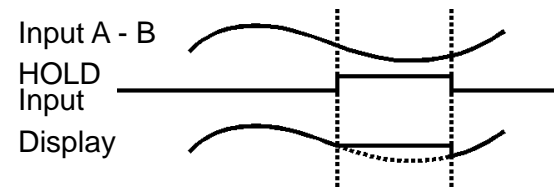

The instrument measures the frequency of input A and input B and executes the following calculation: $display = (F_a/Pu.1*PS.1) - (F_b/Pu.2*PS.2)$

Pu.2*PS.2). This result represents the difference between the input channels and can be used when the speed difference between two conveyor belts has to be as low as possible without considering the reference speed of the first conveyor (in any case within a well known value that can be controlled by the available alarm set-point) in order to avoid any transportation problem of the produced goods.

F3 : $(A - B)/B*100$, frequency (speed) error ratio

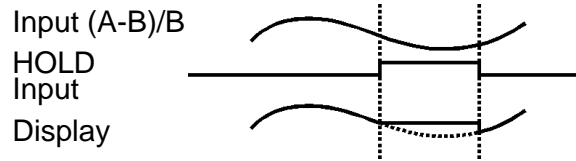

The instrument measures the frequency of input A and input B and executes the following calculation: $display = [(Fa/Pu.1*PS.1) - (Fb/Pu.2*PS.2)] / (Fb/Pu.2*PS.2) * 100$. This result represents the relative error between the 2 input channels; this measuring capability is used when the speed difference between two conveyor belts has to be as low as possible in any case within a well known value that can be controlled by the available alarm set-points. If the instrument is equipped with the analogue output, this signal can be used to correct the speed of the second conveyor belt.

F4 : A/B, frequency (speed) ratio mode

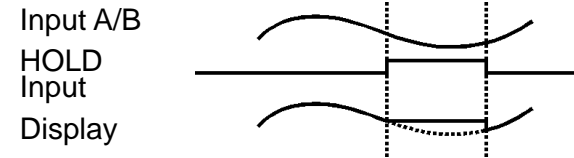

The instrument measures the frequency of input A and input B and executes the following calculation: $display = (Fa/Pu.1*PS.1) / (Fb/Pu.2*PS.2)$. This measuring capability is ideal for monitoring the relative speeds of shafts, conveyor belts and other moving machinery.

F5 : $B/(A+B)*100$

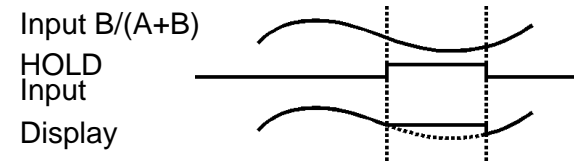

The instrument measures the frequency of input A and input B and executes the following calculation: $display = (Fb/Pu.2*PS.2) / [(Fa/Pu.1*PS.1) + (Fb/Pu.2*PS.2)] * 100$. This measuring capability is used in all the applications where it is necessary to measure a mixture flow between two liquids. If the instrument is equipped with an analogue output, this signal can be transmitted to a paper recorder to show the

mixture deviation that is connected to the quality result of the mixture itself.

F6 : 1/A, period or average period mode

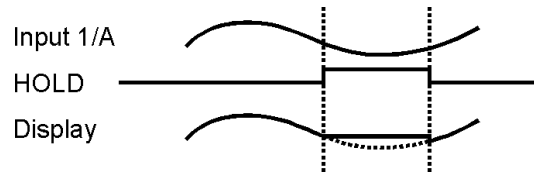

The instrument measures the frequency of input A or input B and executes the following calculation: $display = 1 / (F_a / P_u.1 * PS.1)$. The time period is directly connected to the time base that has been programmed in the instrument (for low frequencies or long time periods):

- if the time base is in the range of the period being measured (see figure below), the updating of the display is as fast as possible and any period changing is updated immediately on the display;

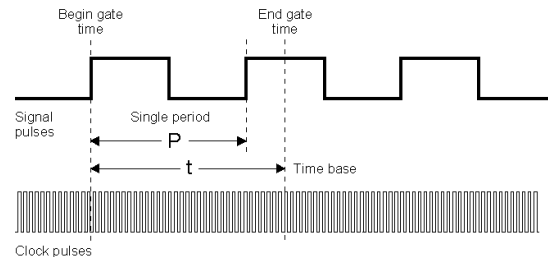

- if the time base is, for instance, three times the period being measured (see figure below), the updating of the display is made at the end of the time base (end gate time) as average calculation of the measured periods $P = (P_1 + P_2 + P_n) / n$

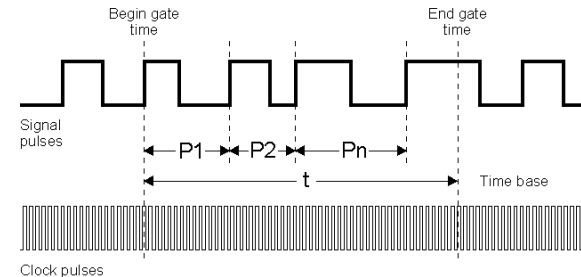

F7 : A, frequency (speed) clockwise and counter clockwise rotation sensing mode.

This measuring capability is ideal for monitoring the relative speed of shafts, conveyor belts and other moving machinery taking into account the rotation mode, showing the reverse speed by means of a "-" sign. The rotation sensing is detected by means of a phase difference, measured using the two input channels available as standard in the instrument. If we assume that the channel A is the main channel (see figure on the next page), the channel B is used to detect if a signal arrives "after" (phase displacement) the signal of the main channel (begin gate time) meaning "clockwise" rotation or "before" meaning

"counter clockwise rotation". Such kinds of signals are normally generated by standard encoders.

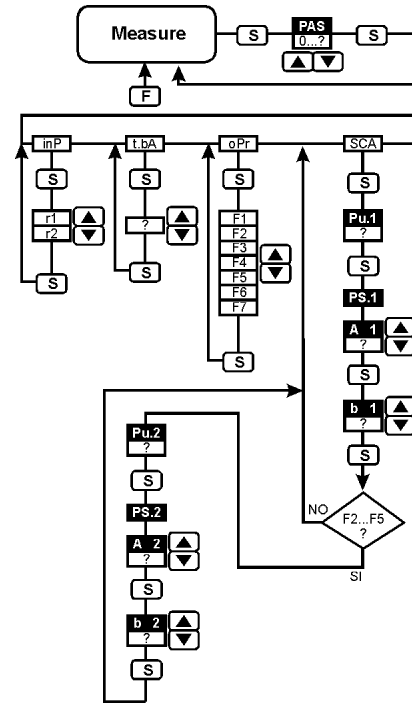
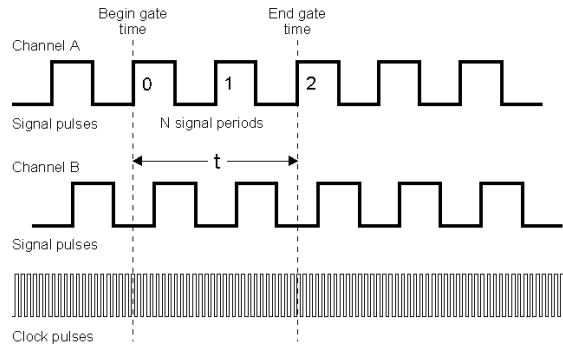

• **SCA**: scaling factor programming menu.

This menu allows to scale the input signals coming from both A and B measuring channels in such a way that they can be shown on the display as a rate, a frequency, a period or a speed.

The parameters that allow to scale this input signals according to the needs are:

Pu.1 : number of pulses per revolution of the sensor (proximity switch) connected to channel A . Programmable value: $1 < Pu.1 < 9999$.

PS.1 : Prescaler channel A stated in the following way: $A1 * 10^{b1}$.

A1 : $1 < A1 < 9999$.

b1 : $-9 < b1 < 9$.

Pu.2 : number of pulses per revolution of the sensor (proximity switch) connected to channel B . Programmable value: $1 < Pu.1 < 9999$.

PS.2 : Prescaler channel B stated in the following way: $A2 * 10^{b2}$

A2 : $1 < A2 < 9999$.

b2 : $-9 < b2 < 9$.

What is the meaning of "prescaler"? It's a multiplier used to multiply the measured frequency by a programmable value in order to achieve the desired value on the display.

To allow the scaling capability of the instrument to be as powerful as possible, this parameter has been divided into two sub parameters: the mantissa "A" and the exponent "b". The prescaler is stated as $A * 10^{b1}$.

The calculation capability is from:

$9999 * 10^{-9}$ (0.000009999) max. divisor;

$1 * 10^{-1}$ (0,1) min. divisor;

$9999 * 10^9$ (9999000000000) max. multiplier;

$1 * 10^0$ (1) min. multiplier.

What is the meaning of "pulses per revolution"? It is the number of pulses that are generated by the input connected sensor for every complete revolution (360°) of the wheel or of the drive shaft being detected.



For instance, if the wheel has 30 cogs (30 references) that can be detected by an inductive proximity switch, at the end of its rotation it generates 30 pulses, so the number that has to be programmed as Pu.1 or Pu.2 parameter is 30. Pay attention: if, instead of a speed or a rate, you have to measure and display a frequency or a period, Pu.1 and Pu.2 have to be "1" (pulse per revolution).

First example:

if you have to measure a speed of a motor with the following data:

motor speed: 800 RPM;

pulses per revolution : 1;

requested displayed value: 800 RPM;

you have to proceed in the following way:

calculate the maximum frequency that is given by:

*"[max. speed (RPM) * pulses per revolution]/60", that takes in our case:*

*"[800 * 1]/60 = 13.33Hz"*

• *"InP": to select the proper input range that is connected to the maximum frequency. You have to measure, in our case, 13.33Hz, therefore the range is "r1" (from 0.001Hz to 500Hz). With the "r1" range you can easily calculate the minimum speed the instrument can measure and display: "[min. frequency (Hz) * 60]/pulses per revolution" that takes in our case "[0.001 * 60]/1=0.06 RPM".*

• *"t.bA": to select the proper time base in order to exploit the maximum performance of the instrument. If the speed of the motor can be adjusted from 100 RPM to 800 RPM we can calculate the time period corresponding to the minimum speed that is given by: "60/[min. speed (RPM) * pulses per revolution]", that takes in our case "60/[100*1]= 0.6"*

sec., therefore the "t.bA" would be "0.6", better if "0.7".

- "oPr": to perform the measurement of a "speed" you have to choose the "F1" function

- "SCA"

- "Pu.1": the number of "pulses per revolution" is in our case "1", therefore "Pu.1" becomes 1.

- "PS.1": the prescaler formed by the two sub-parameters "A1", mantissa, and "b1", exponent, has to be set in the following way: the maximum read-out capacity of the instrument is 9999, that means the speed can be shown as 800.0 "RPM". We have to measure "800" but to obtain the maximum speed resolution we have to display 8000 (don't consider the decimal point). The calculation made by the instrument according to function selection "F1" is the following:

value to be displayed = $(Fa * PS.1) / Pu.1$ (1)

- "Fa" according to the frequency of 800 RPM is 13.33Hz;

- "Pu.1" is 1;

- "PS.1" can be calculated from the above mentioned formula (1) that means: $(\text{value to be displayed} * Pu.1) / Fa$, that makes :

$(800*1) / 13.33 = 60.01$, that means: $60.01 = A1*10^{b1}$

therefore $A1=6001$ and $b1 = -2$ ($10^{b1} \rightarrow 0.01$)

- "dSY": to show on the display 800.0 we have to move the decimal point to "111.1";

- "Lo": see the proper explanation on the next pages;

- "Hi": see the proper explanation on the next pages;

The PS.2 menu is not available for the functions F1, F6 and F7.

Second example:

if you have to measure the speed difference between two wheels, detected by 2 inductive sensors, that have the following data:

Wheel number 1 (connected to the channel "A" of the MDI40):

max rotational speed: 700 RPM;

pulses per revolution: 4.

Wheel number 2 (connected to the channel "B" of the MDI40):

max rotational speed: 600 RPM;

pulses per revolution: 4.

you have to proceed in the following way:

calculate the maximum frequency that is given by:

"[max. speed (RPM) * pulses per revolution]/60", that makes in our case, for wheel 1: $Fa = (700 * 4)/60 = 46.66\text{Hz}$

for wheel 2: $Fb = (600 * 4)/60 = 40.00\text{Hz}$

- "InP": to select the proper input range that is connected to the maximum frequency you have to measure; in our case the value is between 40Hz and 50Hz, therefore the range is "r1" (from 0.001Hz to 500Hz). With the "r1" range you can easily calculate the minimum speed the instrument can measure and display: "[min. frequency (Hz) * 60] / pulses per revolution" that makes in our case "[0.001 * 60]/4=0.015 RPM".

- "t.bA": to select the proper time base in order to exploit the maximum performance of the instrument. If the speed of the two wheels can be adjusted from 100 RPM to 700 RPM (for the first wheel) and from 100 to 600 (for the second one), we can calculate the time period corresponding to the minimum speed that is given by: "60/[min. speed (RPM)* pulses per revolution]", that makes in our case "60/[100*4]=

0.15 sec., therefore the "t.bA" would be "0.15", better if "0.2".

•"oPr": to perform the measurement of a "speed difference" you have to choose the "F2" function

•"SCA"

•"Pu.1": the number of "pulses per revolution" of channel "A", is in our case "4", therefore "Pu.1" becomes 4.

•"PS.1": the prescaler of channel "A", formed by the two sub-parameters "A1", mantissa, and "b1", exponent. It must be equal to the prescaler of channel "B", "PS.2".

•"Pu.2": the number of "pulses per revolution", of channel "B", is in our case "4", therefore "Pu.2" becomes 4.

•"PS.2": the prescaler of channel "B", formed by the two sub-parameters "A2", mantissa, and "b2", exponent. It must be equal to the prescaler of channel "A" and can be calculated in the following way:

the maximum read-out capacity of the instrument is 9999, that means the minimum speed difference (given subtracting the max. speed of channel "A" and the one of channel "B") can be shown as 100.0 "RPM". We want to measure "100" but to have the maximum speed resolution we have to display 1000 (don't consider the decimal point). The calculation made by the instrument according to function selection "F2" is the following:

$$\text{value to be displayed} = [(Fa * PS.1) / Pu.1 - (Fb * PS.2) / Pu.2] \quad (1)$$

- PS.1 = PS.2 = PS that means: A1 = A2 = A and b1 = b2 = b

- Fa according to the frequency of 700 RPM is 46.66Hz;

- Fb according to the frequency of 600 RPM is 40.00Hz;

the prescaler can be calculated from the above mentioned formula (1)

that means: $PS = (\text{value to be displayed} * Pu.1) / (Fa - Fb)$, that makes: $(100 * 4) / 6.66 = 60.06$, that means: $60.06 = A * 10^b$

therefore $A = 6001$ and $b = -2$ ($10^{-2} \rightarrow 0.01$)

•"Pu.2": the number of "pulses per revolution", of channel "B", is in our case "4", therefore "Pu.2" becomes 4.

•"dSY": to show on the display 100.0 we have to move the decimal point to "111.1";

•"Lo": see the proper explanation on the next pages;

•"Hi": see the proper explanation on the next pages:

Parameter table (suggested values)

MEASUREMENT	FUNCTION (oPr)	UNIT (display)	TIME BASE (t.bA)	PULSE / REVOL. (PU.1) (PU.2)	PRESCALER (PS.1) (PS.2)		
Rotational Speed	F1, F2	RPS	1	1	1		
	F3, F4	RPM	60	1	60		
		RPH	60	1	3600		
Linear Speed (circumferential speed)	F1, F2 F3, F4	mm/s	1	1	$1000 * \pi * d$		
		cm/s	1	1	$100 * \pi * d$		
		m/s	1	1	$\pi * d$		
		mm/min	60	1	$1000 * \pi * d * 60$		
		cm/min	60	1	$100 * \pi * d * 60$		
		m/min	60	1	$\pi * d * 60$		
		mm/h	60	1	$1000 * \pi * d * 3600$		
		cm/h	60	1	$100 * \pi * d * 3600$		
		m/h	60	1	$\pi * d * 3600$		
		km/h	60	1	$\pi * d * 3.6$		
		MPH	60	1	$\pi * d * 2.23$		
		Frequency	F1	Hz	1	n	n
				kHz	0,1	n	n / 1000

Where:

d = diameter of the circumference

n = number of pulses per revolution

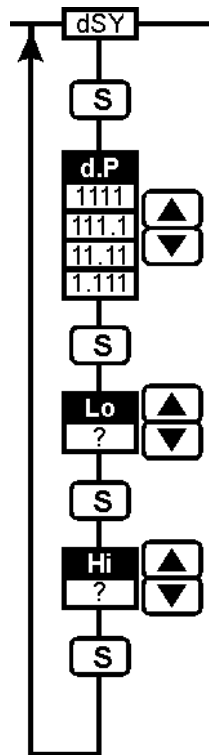

dSY : display parameter programming menu

d.P : decimal point position selection.

Lo : minimum value of the display scale, programmable value: -1999 < Lo < 9999

Hi : maximum value of the display scale, programmable value: -1999 < Hi < 9999

These values are referred only to the output limits of the analogue output and to the "OFF" alarm function.

For instance: if Lo=100.0 and hi=800.0 and the alarm type "TYP" is "OFF", the display will blink and activate the relevant output when the measured variable goes out of the "100.0 to 800.0" limits. If the analogue output is available, the output signals will start from "100.0" and will arrive to "800.0".

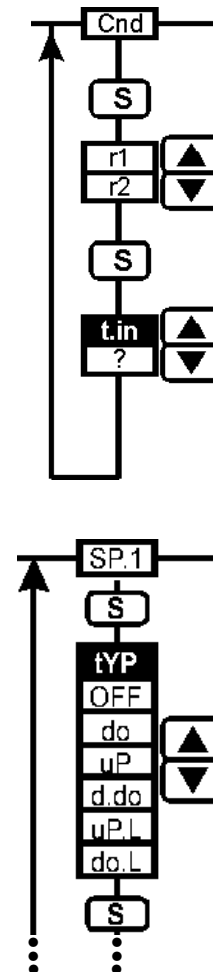

• **Cnd** : auxiliary command selection menu

r1 : display HOLD.

r2 : key-pad disabling.

t.in : activation time of the auxiliary input, programmable value: 20 < t.in < 255 msec.

• **SP.1** / **SP.2** : set-point programming menu

tYP : working type:

oFF : abnormal condition notifying. The output will be activated either when the measurement is out of the measuring range or when it cannot be displayed (blank display or "EEE" / "-" indication on the display).

Note: if the above mentioned function will be selected, the Lo.S, Hi.S, SP1, HYS parameters will not be considered.

do : down alarm.

uP : up alarm.

d.do : down alarm with disabling at power-on.

uP.L : up alarm with latch (the alarm

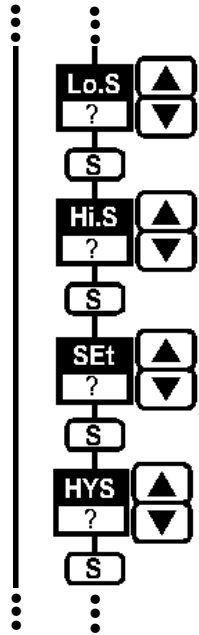

can be reset only if the "F" key will be held down for at least 2 seconds).

do.L: down alarm with latch (the alarm can be reset only if the "F" key will be held down for at least 2 seconds).

Lo.S: value of the lower Set-point limit, programmable value: $Lo(Hi) < LoS < Hi(Lo)$.

Hi.S: value of the upper Set-point limit, programmable value: $Lo.S < Hi.S < Hi(Lo)$

SEt: value of the Set-point; programmable value: $Lo.S < SEt < Hi.S$.

HYS: hysteresis value of the set-point. The hysteresis is a numerical value included within the range: $0 < HYS < 9999$ and represents the difference between the value of the ON alarm status and the value of the OFF alarm status. The hysteresis modifies the value of the OFF alarm status not only with regards to the set alarm value, but also with regards to the alarm type: the hysteresis value is summed to the set value if the alarm type is "do" and subtracted from the set value if the alarm type is "uP".

Example:

"do" alarm, if "SEt"=2200 (value of the ON alarm status) and the hysteresis "HYS"=12, the resulting OFF value (end of alarm status) is: 2212 (resulting from $2200 + 12$).

"uP" alarm, if "SEt"=2200 (value of the ON alarm status) and the hysteresis "HYS"=12, the resulting OFF value (end of alarm status) is: 2188 (resulting from $2200 - 12$).

NOTE: the hysteresis is to be programmed according to the displayed range. This means that the hysteresis must always be much lower than the displayed range.

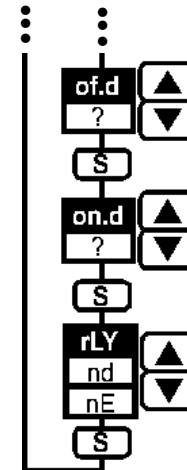

of.d: OFF time delay; programmable value: $0 < OF.d < 255$.

on.d: ON time delay; programmable value: $0 < On.d < 255$.

rLY: coil status of the relay in the normal condition:

nd: normally de-energized coil.

nE: normally energized coil.

Note: the normally closed or open status of the alarm contact is modified by means of an inside selectable solder jumper.

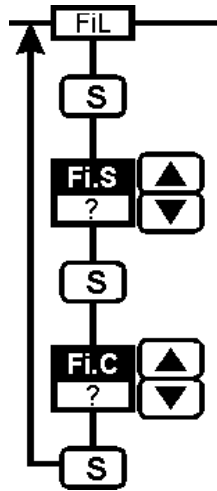

- **FiL**: filter parameter programming menu.

This function allows you to stabilize the instruments digital display, in order to obtain steady readings and better control.

Fi.S: filter working range. The coefficient is given in digits and defines the range in which the filter works, programmable value: $0 < \text{Fi.S} < 9999$

The programmable numerical value represents the fluctuation range of the value which has been measured and displayed by the instrument. In the first configuration phase this value must be 0 and the right value is to be entered only after the verification of the possible fluctuation.

Example: if the measured instantaneous value varies from 10.00 to 10.06, the "Fi.S" value to be entered is 0.06 (10.06 - 10.00).

Fi.C: filtering coefficient value. Programmable value: $1 < \text{Fi.C} < 255$.

The higher "Fi.C", the higher the filtering of the measured value and the longer the updating time of the dis-

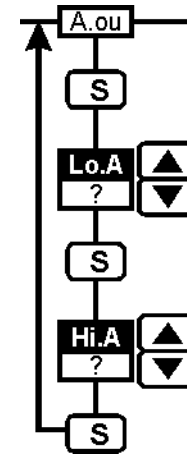

played value, the control set-points and the analogue output.

NOTE: for a correct working of the filter, the relative coefficient must satisfy the following relationship: $1 < \text{Fi.C} < (\text{Fi.S} \times 8) < 255$.

- **A.ou**: analogue output programming menu.

Lo.A: value to be expressed as % of the output range (0/20mA-0/10V) to be generated in correspondence with the minimum measured value. Value programmable within the range: $0.00 < \text{Lo} < 99.99$.

Hi.A: value expressed as % of the output range (0/20mA-0/10V) to be generated in correspondence with the maximum measured value (Hi.E/Hi parameters). Value to be programmed within the range: $0.00 < \text{Hi.A} < 99.99$.

Example: minimum measured value = 100, that must correspond to a retransmitted signal of 4mA.

"Lo.A" (%) = $\frac{100 * ?mA}{20}$ that in our example corresponds to:

20

$100 * 4mA/20 = 20\%$, therefore enter 20.00.

Example: minimum measured value = 100, that must correspond to a retransmitted signal of 1V.

“Lo.A” (%) = $\frac{100 * ?V}{10}$ that in our example corresponds to:

$100 * 1V/10 = 10\%$, therefore enter 10.00.

Example: maximum measured value 800, that must correspond to a retransmitted signal of 18mA.

“Hi.A” (%) = $\frac{100 * ?mA}{20}$ that in our example corresponds to:

$100 * 18mA/20 = 90\%$, therefore enter 90.00.

Example: maximum measured value 800, that must correspond to a retransmitted signal of 5V.

“Hi.A” (%) = $\frac{100 * ?V}{10}$ that in our example corresponds to:

$100 * 5V/10 = 50\%$, therefore enter 50.00.

Also in this case it is possible to invert the scale, that is, a decreasing value of the retransmitted signal may correspond to an increasing value of the input variable (example: Lo.A > Hi.A).

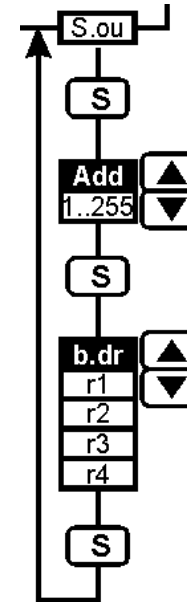

• **S.ou**: selection menu of the serial communication output.

Add: programmable address value:
1 < Add < 255

b.dr: programming of the data baud rate:

r1: 1200 bps.

r2: 2400 bps.

r3: 4800 bps.

r4: 9600 bps.

