

Channel Generators

Types GPD 1901, G 3490 0000



- Generates 8, 16, 24, 32, 40, 48, 56, 64, 96 or 128 channels
- Number of channels selectable by rotary switch
- Number of sequences (1 or 2) selectable
- Quartz-controlled oscillator
- Cable compensation
- Plug-in type (GPD)
- DIN-rail mounting type (G3490) (EN 50022)
- LED-indication for supply and Dupline® carrier
- AC or DC power supply

Product Description

Standard channel generators for all Dupline® systems. Number of channels selectable by means of a rotary switch.

Ordering Key

GPD 1901 024

Type: Dupline®
 Channel generator
 Supply

Type Selection

Supply	Ordering no. No. of channels selectable	Ordering no. No. of channels selectable
24 VAC	GPD 1901 024	G 3490 0000 024
120 VAC	GPD 1901 120	G 3490 0000 115
220 VAC	GPD 1901 220	G 3490 0000 230
15 to 30 VDC	GPD 1901 824	G 3490 0000 824

Input/Output Specifications

Inputs	Outputs (cont.)
Function	Sequence time *
Open loop voltage	No. of channels:
Short-circuit current	8
Contact resistance	16
Cable length	24
Insulation voltage	32
Input - Dupline®	40
	48
	56
	64
	96
	128
	Distance to transmitters
	100%
	(refer to "Cable Selection")

* When using 2 sequences, the sequence time will be 2 times higher.

Supply Specifications

Power supply AC types		Overvoltage cat. III (IEC 60664)
Rated operational voltage through term.: 21 & 22 (G3490) or A1 & A2 (GPD1901)	230 115 024	230 VAC ± 10% (IEC 60038) 115 VAC ± 10% (IEC 60038) 24 VAC ± 10%
Frequency		45 to 65 Hz
Power dissipation		4 W
Voltage interruption		≤ 40 ms
Rated operational power		Typ. 2.5 VA
Rated impulse withstand voltage	230 115 024	4 kV 2.5 kV 800 V
Dielectric voltage Supply - Dupline® Supply - Inputs		≥ 4 kVAC (rms) ≥ 4 kVAC (rms)
Power supply DC types		Overvoltage cat. III (IEC 600664)
Rated operational voltage through term.: 21 & 22 (G3490) or A1 & A2 (GPD1901)	824	15 to 30 VDC (ripple included)
Power dissipation		3 W
Ripple		≤ 3 V
Reverse polarity protection		Yes
Current consumption		≤ 90 mA
Inrush current		≤ 1 A
Rated impulse withstand voltage		800 V
Dielectric voltage Supply - Dupline® Supply - Input		None ≥ 200 VAC (rms)

General Specifications

Power ON delay	≤ 3 s
Indication for Supply ON Dupline® carrier	LED, green LED, yellow
Environment Degree of protection Pollution degree Operating temperature Storage temperature	IP 20 3 (IEC 60664) -20° to +50°C (-4° to +122°F) -50° to +85°C (-58° to +185°F)
Humidity (non-condensing)	20 to 80%
Mechanical resistance Shock Vibration	15 G (11 ms) 2 G (6 to 55 Hz)
Dimensions Material (see "Technical Information")	D-housing, H4-housing
Weight	250 g

Mode of Operation

The channel generators generate pulse trains and synchronize the transmission signals for an entire system of Dupline® modules. At the same time they supply non-powered Dupline® transmitters.

The selection of 1 or 2 sequences means that 1 or 2 consecutive signals of a transmitter must show identical status until the channel generator changes the duty cycle for the respective channel. This change of duty cycle causes the receivers to change their status.

Note:

- Do not use 2 sequences if analog modules or counters are connected to the system.
- The transmission distance of a Dupline® network is reduced by 33% when using 2 sequences, compared to the figures given under "Cable Selection".

In Dupline® systems with digital transmitters and receivers the use of 2 sequences is only recommended in cases of extremely long cabling in high noise level environment. Application of 2 sequences

results in absolutely correct transmission but also in a slow reaction time for the system.

HF disturbance that is induced to the Dupline® may be suppressed by interconnection of pins 4 & 6 (GPD 1901) or terminals 4 & 1 (G 3490 0000). For inductive cables a separate capacitor of less than 1 µF may be mounted between pins 3 & 6 (GPD 1901) or terminals 1 & 2 (G3490 0000). But in the majority of cases the cable appears to be capacitive requiring no additional capacitor.

Note: It is highly recommended to place the channel generator in the middle of a Dupline® system.

Operation Diagram

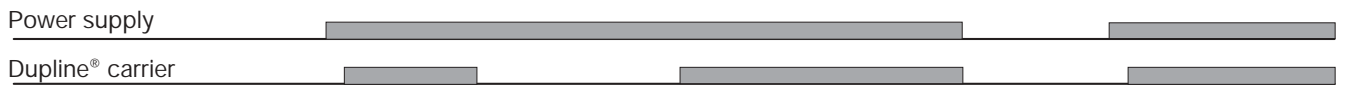

Wiring Diagrams

GPD 1901

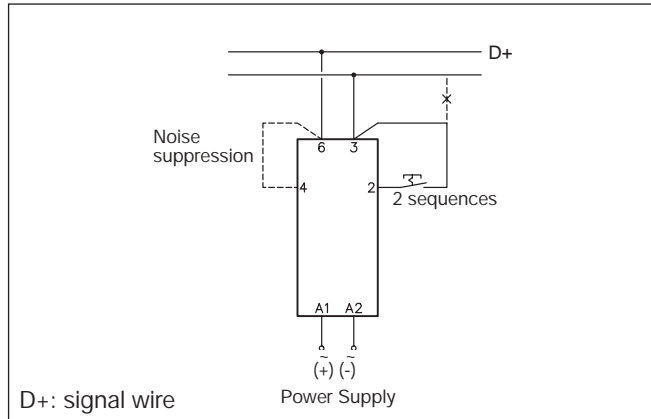

G 3490 0000

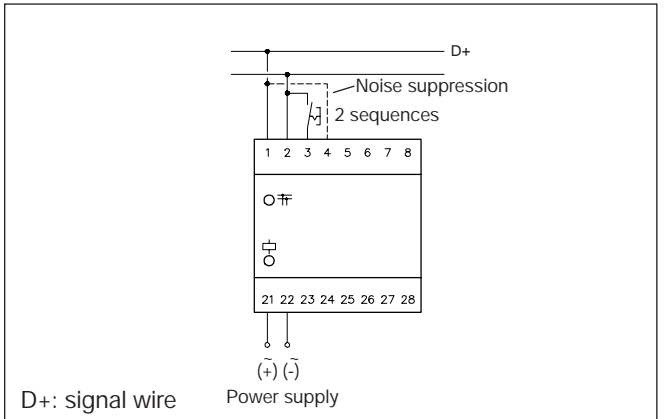

Accessories

Socket◊	D 411
Socket cover	BB 5
Hold down spring◊	HF
Front mounting bezel	FRS 2
DIN-rail for D 411	FMD 411

For further information refer to "Accessories".