

Universal Analog Output Module for DIN-Signals

Type G 3439 6470

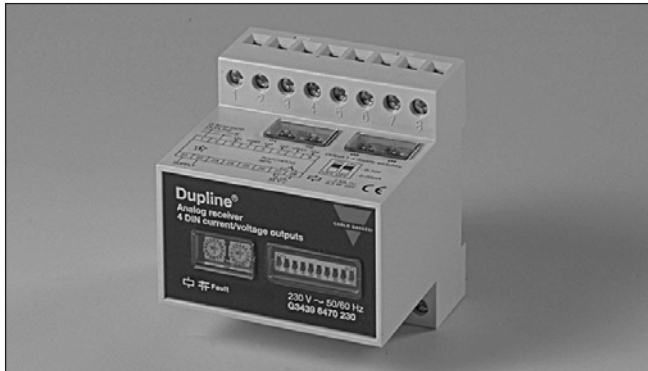

- 4 analog outputs
- Outputs individually configurable for 0-20 mA, 4-20 mA or 0-10 VDC
- Selectable resolution: 1/1999 or 1/255 of full scale
- Selectable dataformat : 8-bit, AnaLink or 3 1/2 digit BCD
- EMC immunity according to EN50082-2 (industrial environment)
- DIN-rail mounting (EN 50022)
- Address-selection through rotary switches
- LED-indication for supply and Dupline® carrier
- LED-indication for invalid switch setting and faulty received data
- Watchdog output for faulty received data
- H4 housing

Product Description

Dupline® 4 output universal analog output module with internal supply. The module receives signals on a digital format from Dupline® and converts them to analog outputs. The output type can be selected as 0-20 mA, 4-20 mA or 0-10 VDC for each output individually making a mix of analog output types on

the same module possible. The transmission format on Dupline® can be selected to fit the output module into existing installations, or simply to use the most suitable combination of resolution, signalling capacity and speed. The formats are: 8-bit binary, AnaLink and 3 1/2 digit BCD (with or without multiplexing).

Ordering Key

G 3439 6470 024

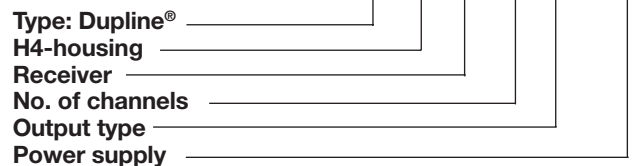

Type Selection

Supply

24 VAC
115 VAC
230 VAC
10-30 VDC

Ordering no.

G 3439 6470 024
G 3439 6470 115
G 3439 6470 230
G 3439 6470 800

Output Specifications

| | Outputs set to voltage | Outputs set to current |
|--|--|--|
| Signal | | |
| Signal output | DIN-voltage output | DIN-current output |
| Signal range | 0-10 VDC | 0-20 mA / 4-20 mA |
| Output load | ≥ 100 kΩ | 0-450 Ω |
| Short circuit protection | Yes | Yes |
| Watchdog output | ≤ 30 V | ≤ 50 mA |
| Resolution | | |
| A/D | 11 bits or 8 bits | 11 bits or 8 bits |
| Transmission | 1/1999 or 1/255 | 1/1999 or 1/255 |
| Output settling time | ≤ 0.5 sec. | ≤ 0.5 sec |
| Inaccuracy (11-bit) (ref. temp. 25°C) | < 0.4% of full-scale < 0.2% of reading < 1 count | < 0.4% of full-scale < 0.2% of reading < 1 count |
| Temperature influence (ref. temp. 25°C) | < ±15 ppm/K of full-scale < ±150 ppm/K of reading | < ±15 ppm/K of full-scale < ±150 ppm/K of reading |
| Recommended cable length | < 25 m | < 25 m |
| Dielectric voltage | | |
| Output - Dupline® | 250 VAC (rms) | 250 VAC (rms) |
| Output - Watchdog output | 2 kVAC (rms) | 2 kVAC (rms) |

Supply Specifications

| | |
|---|------------------------------------|
| Power supply AC-types | Overvoltage cat. III (IEC 60664) |
| Operational voltage through term. 21 & 22 | 230 230 VAC, -10/+15 % (IEC 60038) |
| 115 | 115 VAC, -10/+15 % (IEC 60038) |
| 024 | 24 VAC, -10/+15 % |
| Frequency | 45 to 65 Hz |
| Power consumption | typ. 7 VA |
| Power dissipation | ≤ 8 W |
| Rated impulse withstand voltage | 230 4 kV |
| 115 | 2.5 kV |
| 024 | 800 V |
| Dielectric Voltage | |
| Supply - Dupline® | 4 kVAC (rms) |
| Supply - Signal output | 4 kVAC (rms) |
| Supply - Watchdog output | 4 kVAC (rms) |
| Power supply DC-types | |
| Operational voltage through term. 21 & 22 | 800 10,5 V - 30 VDC (Ripple incl.) |
| Ripple | < 3 V |
| Reverse polarity protection | Yes |
| Power consumption | < 4 W |
| Power dissipation | < 6 W |
| Rated impulse withstand voltage | 800 V |
| Dielectric Voltage | |
| Supply - Dupline® | 500 VAC (rms) |
| Supply - Signal output | 250 VAC (rms) |
| Supply - Watchdog output | 2 kVAC (rms) |

General Specifications

| | |
|--|-------------------------------|
| Power ON delay | ≤ 2 s |
| Indication for | |
| Supply ON | LED, green |
| Dupline® carrier | LED, yellow |
| Dupline® format error | LED, red |
| Illegal switch setting | LED, red - flashing |
| Environment | |
| Degree of protection | IP 20 |
| Pollution degree | 3 (IEC 60664) |
| Operating temperature | 0° to +50°C (+32° to +122°F) |
| Storage temperature | -20° to +85°C (-4° to +185°F) |
| Humidity (non-condensing) | 20 to 80% |
| Mechanical resistance | |
| Shock | 15 G (11 ms) |
| Vibration | 2 G (6 to 55 Hz) |
| Dimensions | |
| Material (see Technical information) | H4-Housing |
| Weight | 300 g |
| CE-marking | Yes |

Switch Settings

Shunt-switches on system top

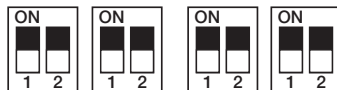

Current shunts on output 1-4:
ON/ON = 0-10 V / (2-10 V)
OFF/OFF = 0-20 mA / 4-20 mA

Rotary switches in the front

| | | |
|---------------------|--|---|
| Mode | <input type="checkbox"/> A-P | <input type="checkbox"/> 0-F |
| 3 1/2 digit: | Channel group-pair Ex. setting: C or D = C-D | Mux. address for output 1, rest of the outputs (if enabled) on the following addresses |
| 8-bit: | Channel group | Same as 3 1/2 digit. Ex. setting 5 (with 2 outputs enabled) = Output 1 on mux address 5 Output 2 on mux address 6 |
| Analink: | Channel group | Channel no. for output 1, rest of the outputs (if enabled) on the following channels. Setting of 0+9-F is not valid. |

Function switches in the front

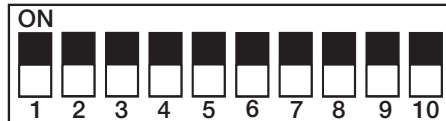

Offset on output 1-4

ON = 4-20 mA / (2-10 V)
OFF = 0-20 mA / 0-10 V

No. of enabled outputs

OFF ON : 1
ON OFF : 2
ON ON : 3
OFF OFF : 4

Mode (Format)

OFF OFF : Analink
OFF ON : 8-bit binary
ON OFF : 3 1/2 digit BCD
ON ON : Reserved for future use

Multiplex ON/OFF

(Only used in 3 1/2 digit BCD and 8-bit binary mode)
ON = Data is multiplexed

OFF = Data to output 1 is received on the group (or grouppair) rotarysw. A-P is set to,
data from input 2, 3, 4 (if enabled) on the following groups (or grouppairs)

Maintain ON/OFF

ON = Keep output in case of Dupline® (or format) error
OFF = Zero output in case of Dupline® (or format) error

Wiring Diagram

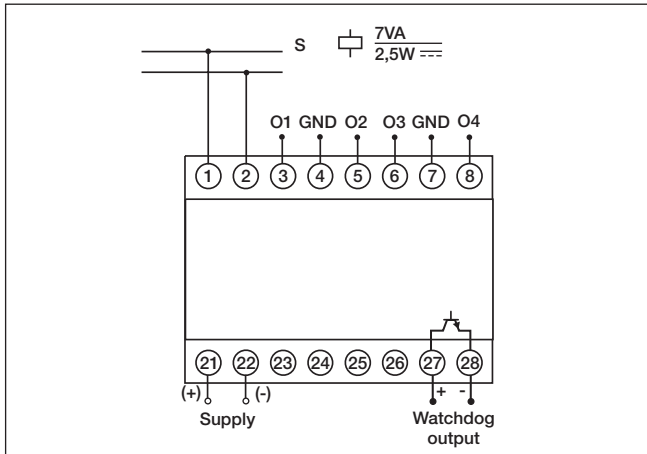

Dimensions (mm)

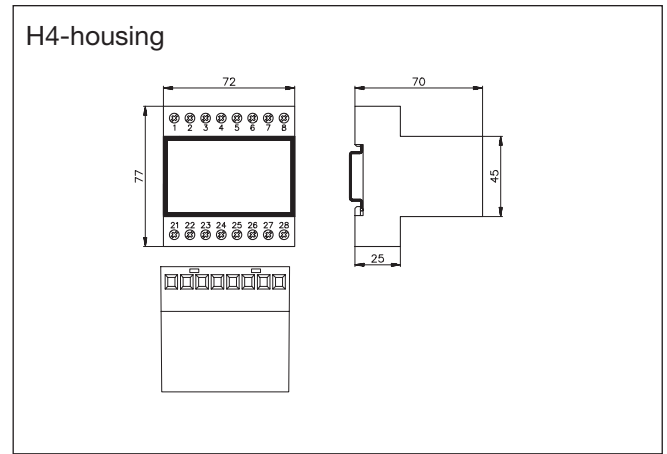

Mode of Operation

The G34396470 is a universal analog module with 4 outputs. The outputs can be configured individually for 0-20 mA, 4-20 mA or 0-10 VDC signals, making a mix of analog output types on the same module possible. The transmission format is selectable and supports all Dupline analog protocols: 8-bit, AnaLink and 3 1/2 digit BCD. The module can be used in normal or multiplexed mode. Address coding is done by means of rotary switches and the output and protocol selection is done by means of DIP-switches, so the GAP 1605 Programmer is not required.

With reference to the diagram on the previous page, the setting of the module should be performed in the following way:

Select current or voltage signal for each output by means of the 4 double-DIP-switches on the top of the module. If 4-20 mA is desired for an output select off-set ON for the corresponding switch on the front of the module. The module only outputs signals according to the selected

number of enabled outputs on switches 5 and 6.

Address allocation for the Analink protocol:

If all four outputs are enabled, the module will use four Dupline channels in consecutive order, starting from the address set on the two rotary switches on the front of the unit.

Example: Setting of "D7" means that output 1 receives on Dupline channel D7, output 2 receives on D8, output 3 receives on E1 and output 4 receives on E2.

Address allocation for the 8-bit binary protocol:

If all four outputs are enabled and non-multiplexed mode is selected (switch 9), the module will use four Dupline channel groups (32 channels) in consecutive order, starting from the group set on the first rotary switch (A-P). The second rotary switch (0-F) is not used in this mode.

Example: Setting of "F" on the first rotary switch means that output 1 receives on Dupline group F, output 2 receives on G, output 3 receives on H and output 4 receives on I.

If multiplexed mode is selected the module will use one Dupline channel group (8 channels). The first rotary switch (A-P) is used to set the group and the second rotary switch (0-F) to set the multiplex address to be used by the first output, no. 1.

Example: Setting of "F" on the first rotary switch and "0" on the second, means that output 1 receives on Dupline group F mux. adr. 0, output 2 receives on F mux. adr. 1, output 3 receives on F mux. adr. 2 and output 4 receives on F mux. adr. 3.

Address allocation for the 3 1/2 digit BCD protocol:

If all four outputs are enabled and non-multiplexed mode is selected (switch 9) the module will use four Dupline channel group-pairs (64 channels) in consecutive order. The first rotary switch (A-P) is used to set the start group pair. The second rotary switch (0-F) has no function in this mode.

Example: Setting of "C" or "D" on the first rotary switch means that output 1 receives on Dupline group-pair C-D, output 2 receives on E-F,

output 3 receives on G-H and output 4 receives on I-J.

If multiplexed mode is selected the module will use one Dupline channel group-pair (16 channels). The first rotary switch (A-P) is used to set the group-pair and the second rotary switch (0-F) to set the multiplex address to be used by the first output, no. 1.

Example: Setting of "C" or "D" on the first rotary switch and "8" on the second, means that output 1 receives on Dupline group-pair C-D mux. adr. 8, output 2 receives on C-D mux. adr. 9, output 3 receives on C-D mux. adr. A and output 4 receives on C-D mux. adr. B.

Note

The selected protocol is valid for all enabled outputs. The module can not receive different protocols at the same time.

Analog receivers must not be used in systems where channel generators with 2 or 3 sequences are installed.

Accessories

DIN Rail

FMD 411

For further information refer to "Accessories".