

Universal Analog Input Module for DIN-Signals Type G 3429 6470



- 4 isolated analog inputs
- Inputs individually configurable for 0-20 mA, 4-20 mA or 0-10 VDC
- Selectable resolution: 1/1999 or 1/255 of full scale
- Selectable data format: 8-bit binary, Analink or 3 1/2 digit BCD
- EMC immunity according to EN 50082-2 (industrial environment)
- DIN-rail mounting (EN 50022)
- Address-selection through rotary-switches
- LED-indication for Supply and Dupline® carrier
- LED-indication for invalid switch setting and 4-20 mA underflow
- AC or DC power supply

Product Description

Dupline® 4 input universal analog input module for external supply. Analog values on the inputs are converted to digital values and transmitted on Dupline®. Inputs are isolated individually to prevent ground-loops and to simplify installation. The input type can be selected as 0-20 mA, 4-20 mA or 0-10 VDC for each input individually

making a mix of analog input types on the same input module possible. The transmission format on Dupline® can be selected to fit the input module into existing installations, or simply to use the most suitable combination of resolution and speed. The formats are: 8-bit binary, Analink and 3 1/2 digit BCD (with or without multiplexing).

Ordering Key

G 3429 6470 024

Type: Dupline® _____
 H4-housing _____
 Transmitter _____
 No. of channels _____
 Input type _____
 Power supply _____

Type Selection

Supply

24 VAC
 115 VAC
 230 VAC
 10-30 VDC

Ordering no.

G 3429 6470 024
 G 3429 6470 115
 G 3429 6470 230
 G 3429 6470 800

Input Specifications

	Inputs set to voltage measurement	Inputs set to current measurement
Signal Signal input Signal range Max. input level Input resistance	DIN-voltage input 0-10 VDC 50 V 125 KΩ	DIN-current input 0-20 mA / 4-20 mA 50 mA 100 Ω shunt resistor
Resolution A/D Transmission Settling time t_s Inaccuracy (ref. temp. 25°C) Temperature influence (ref. temp. 25°C) Common mode rejection CMRR Input-Input Normal mode rejection Cable length	11 bits or 8 bits 1/1999 or 1/255 ≤ 3 s < ±0.05% of full-scale < ±0.2% of reading < ±1 count < ±10 ppm/K of full-scale < ±50 ppm/K of reading > 120 dB (50-60 Hz) > 80 dB (50-60 Hz) > 45 dB (50-60 Hz) < 25 m	11 bits or 8 bits 1/1999 or 1/255 ≤ 3 s < ±0.05% of full-scale < ±0.2% of reading < ±1 count < ±10 ppm/K of full-scale < ±50 ppm/K of reading > 120 dB (50-60 Hz) > 80 dB (50-60 Hz) > 45 dB (50-60 Hz) < 25 m
Dielectric voltage Input - Input Input - Dupline®	250 VAC (rms) 250 VAC (rms)	250 VAC (rms) 250 VAC (rms)

Supply Specifications

Power supply AC-types	Overvoltage cat. III (IEC 60664)
Rated operational voltage through term. 21 & 22	230
115	230 VAC, ±15 % (IEC 60038)
024	115 VAC, ±15 % (IEC 60038)
Frequency	24 VAC, ±15 %
Power consumption	45 to 65 Hz
Transient protection	typ. 5 VA
230	4 kV
115	2.5 kV
024	800 V
Dielectric Voltage	
Supply - Dupline®	≥ 4 kVAC (rms)
Supply - Signal input	≥ 4 kVAC (rms)
Power supply DC-types	Overvoltage cat. III (IEC 60664)
Rated operational voltage through term. 21 & 22	800
Ripple	10.5 V - 30 VDC (Ripple incl.)
Reverse polarity protection	< 3 V
Power consumption	Yes
Rated impulse withstand voltage	<1.7 W
Dielectric Voltage	800 V
Supply - Dupline®	500 VAC (rms)
Supply - Signal input	250 VAC (rms)

General Specifications

Power ON delay	4 s
Indication for	
Supply ON	LED, green
Dupline® carrier ON	LED, yellow
Underflow (4-20 mA)	LED, red
Illegal switch setting	LED, red - flashing
Environment	
Degree of protection	IP 20
Pollution degree	3 (IEC 60664)
Operating temperature	0° to +50°C (+32° to +122°F)
Storage temperature	-20° to +85°C (-4° to +185°F)
Humidity (non-condensing)	20 to 80%
Mechanical resistance	
Shock	15 G (11 ms)
Vibration	2 G (6 to 55 Hz)
Dimensions	
Material	
(see Technical information)	H4-Housing
Weight	300 g
CE-marking	Yes

Switch Settings

Shunt-switches on system top

Current shunts on input 1-4:
 ON = 0-20 mA / 4-20 mA
 OFF = 0-10 V

Rotary switches in the front

Mode	A-P	0-F
3 1/2 digit:	Channel group-pair Ex. setting: C or D = C-D	Mux. address for input 1, rest of the inputs (if enabled) on the following addresses
8-bit:	Channel group	Mux. address for input 1, rest of the inputs (if enabled) on the following addresses
Analink:	Channel group	Channel no. for input 1, rest of the inputs (if enabled) on the following channels. Setting of 0+9-F is not valid.

Function switches in the front

Offset on input 1-4
 ON = 4-20 mA
 OFF = 0-20 mA / 0-10 V

No. of enabled inputs
 OFF ON : 1
 ON OFF : 2
 ON ON : 3
 OFF OFF : 4

Mode (Format)
 OFF OFF : Analink
 OFF ON : 8-bit binary
 ON OFF : 3 1/2 digit BCD
 ON ON : Reserved for future use

Multiplex ON/OFF
 (Only used in 3 1/2 digit BCD and 8-bit binary mode)
 ON = Data is multiplexed
 OFF = Data from input 1 is transmitted on the group (or grouppair) rotarysw. A-P is set to, data from input 2, 3, 4 (if enabled) on the following groups (or grouppairs)

Reserved for future use
 Don't care

Wiring Diagram

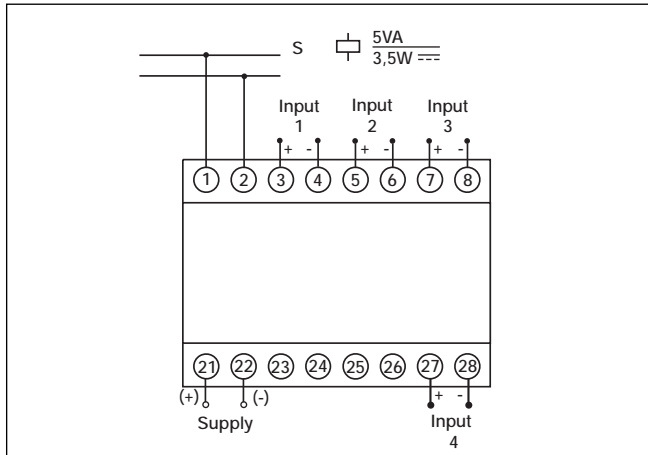

Mode of Operation

The G3429 6470 is a universal analog input module with 4 inputs. Each input can be configured individually to current or voltage measurement. The transmission format is selectable and supports all Dupline® analog protocols Analink, 8-Bit or 3 1/2 digit BCD. Coding of the module is solely done by dip- and rotary-switches located on the module, so the GAP 1605 programmer is not needed.

With reference to the diagram on the previous page, the setting of the module should be performed in the following way:

Please note that **no** signals must be applied to the inputs before the correct mode (current or voltage) is selected by means of the 4 shunt switches on the top of the system. Set the range of each input (0/4-20 mA or 0/2-10 V) by means of the switches 1-4 on the front of the module, and select the actual number of inputs used with switches 5 and 6.

The module only take up Dupline® addresses according to the number of enabled inputs, and the selected transmission protocol (mode) set by switches 7 and 8.

Address allocation for the Analink protocol:

If all four inputs are enabled, the module will use four Dupline® channels in consecutive order, starting from the address set on the two rotary switches on the front of the unit.

Example: Setting of “D7” means that input 1 transmits on Dupline® channel D7, input 2 transmits on D8, input 3 transmits on E1 and input 4 transmits on E2.

Address allocation for the 8-bit binary protocol:

If all four inputs are enabled and non multiplexed mode is selected (switch 9), the module will use four Dupline® channel groups (32 channels) in consecutive order, starting from the group set on the first rotary switch (A-P). The second rotary switch (0-F) is not used in this mode.

Example: Setting of “F” on the first rotary switch means that input 1 transmits on Dupline® group F, input 2 transmits on G, input 3 transmits on H and input 4 transmits on I.

If multiplexed mode is selected the module will use one Dupline® channel group (8 channels). The first rotary switch (A-P) is used to set

Accessories

DIN Rail

FMD 411

For further information refer to “Accessories”.

the group and the second rotary switch (0-F) to set the multiplex address to be used by the first input, no. 1.

Example: Setting of “F” on the first rotary switch and “0” on the second, means that input 1 transmits on Dupline® group F mux. adr. 0, input 2 transmits on F mux. adr. 1, input 3 transmits on F mux. adr. 2 and input 4 transmits on F mux. adr. 3.

Address allocation for the 3 1/2 digit BCD protocol:

If all four inputs are enabled and non-multiplexed mode is selected (switch 9) the module will use four Dupline® channel group-pairs (64 channels) in consecutive order. The first rotary switch (A-P) is used to set the start group pair. The second rotary switch (0-F) has no function in this mode.

Example: Setting of “C” or “D” on the first rotary switch means that input 1 transmits on Dupline® group-pair C-D, input 2 transmits on E-F, input 3 transmits on G-H and input 4 transmits on I-J.

If multiplexed mode is selected the module will use one Dupline® channel group-pair (16 channels). The first rotary switch (A-P) is used to set the group-pair and the

second rotary switch (0-F) to set the multiplex address to be used by the first input, no. 1.

Example: Setting of “C” or “D” on the first rotary switch and “8” on the second, means that input 1 transmits on Dupline® group-pair C-D mux. adr. 8, input 2 transmits on C-D mux. adr. 9, input 3 transmits on C-D mux. adr. A and input 4 transmits on C-D mux. adr. B.

Note

The selected transmission protocol is valid for all enabled inputs. The module can not transmit different protocols at the same time.

Analog transmitters must not be used in systems where channel generators with 2 or 3 sequences are installed.

Dimensions (mm)

D-housing

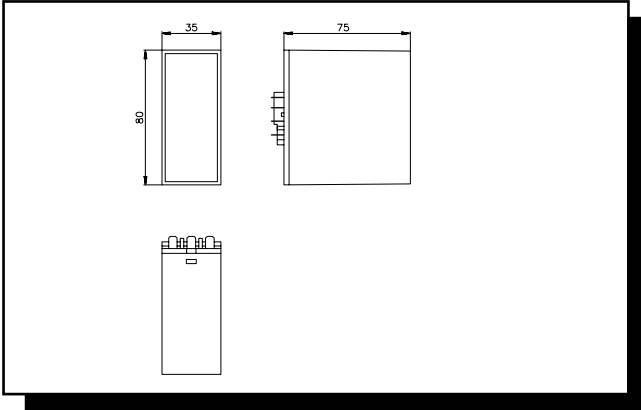

H1/H2-housing

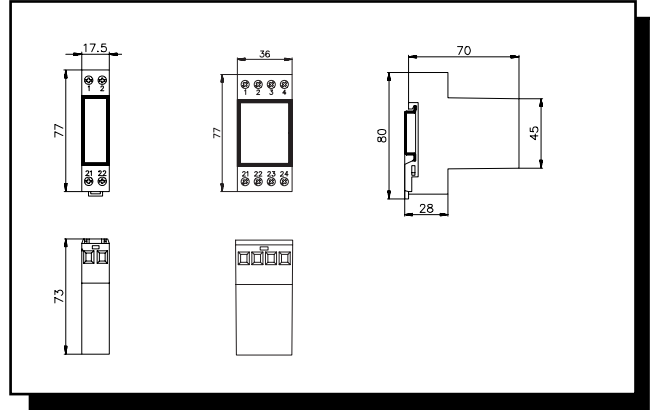

H4-housing

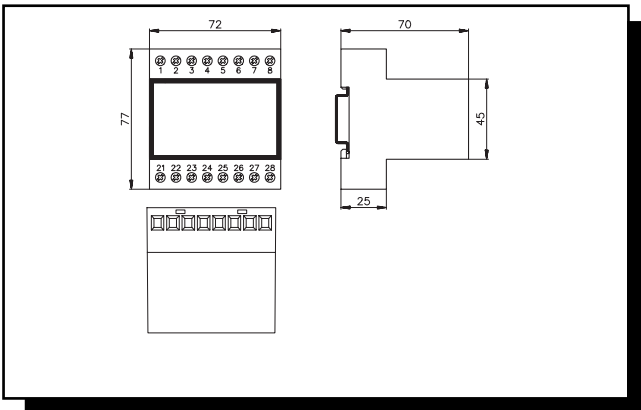

H8-housing

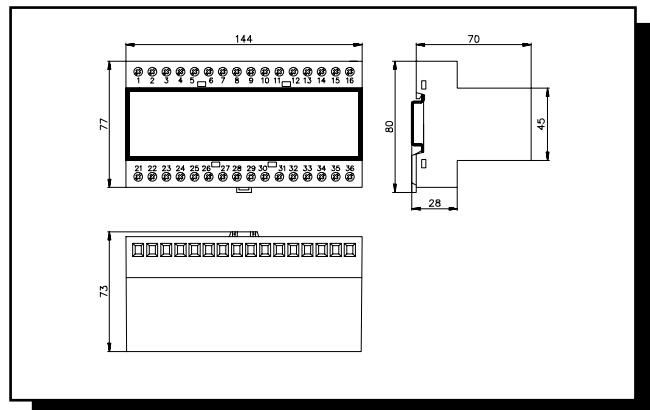

96 x 48-housing

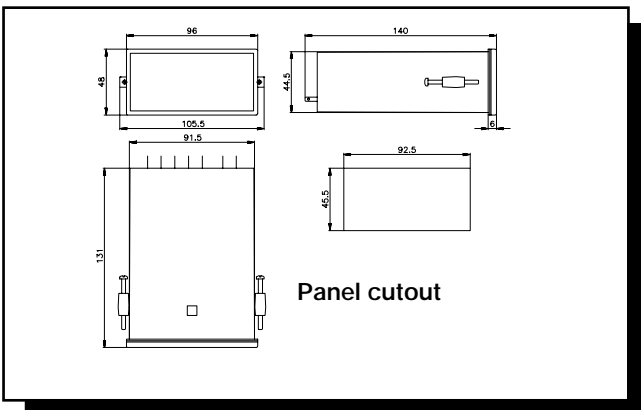

144 x 48-housing

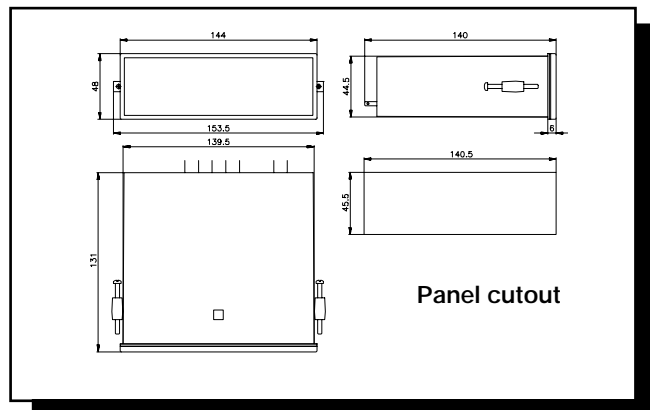

Mini-E Housing

