

I/O-Module for Elevators Type G 2140 4421 700

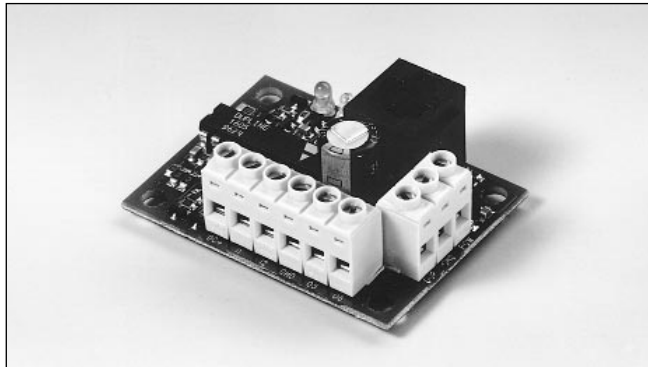

- 2 push-button inputs
- 2 PNP-transistor outputs
- Open printed circuit board
- Small size (54 x 40 mm)
- LED-indications for supply and Dupline® carrier
- DC-supply
- 3-wire system with Dupline® and supply of module and output load through G 2196 0000 700
- Channel coding by GAP 1605

Product Description

Direct interface to the I/O's of elevator floor stations. The input pulses are prolonged to 0.5 s to ensure transfer of fast push-button activations. Due to the small size of the module it can be integrated into most push-button panels. All modules in an eleva-

tor is connected to the same 3 wires for bus communication with the control system and DC power supply for the lamps. Installerfriendly mounting, operation and maintenance without requirements for any special tools or programming.

Ordering Key

G 2140 4421 700

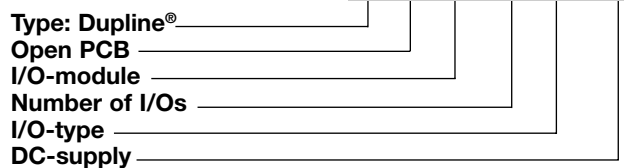

Type Selection

Supply	Ordering no. PNP-outputs
10-30 VDC	G 2140 4421 700

Output Specifications

Outputs	2 PNP-transistors
Output voltage drop	≤ 2.0 V
Current per output	≤ 200 mA
Short circuit protection	None
Built-in protective diodes	Yes
Off-state leakage current	≤ 200 µA
Response time	1 pulse train (136 ms @ 128 channels)

Input Specifications

Inputs	2 contacts or NPN-transistor
Open loop voltage	8.0 VDC
Short circuit current	17 µA
Start peak current	20 mA
Contact resistance	≤ 100 Ω
Cable length	≤ 3 m
Response time	≤ 156 ms @ 128 channels
Input pulse prolongation	Typ. 0.5 s

Supply Specifications

Power supply	Overvoltage cat. III (IEC 60664)
Rated operational voltage (V_{in})	10-30 VDC (ripple included)
Ripple	≤ 3 V
Reverse polarity protection	Yes
Current consumption	≤ 30 mA
Power dissipation	≤ 1 W
Inrush current	≤ 1 A
Transient protection voltage	800 V
Dielectric voltage	
Supply - Dupline®	None
Supply - Inputs	None
Supply - Outputs	None

General Specifications

Power ON delay	Typ. 2 s
Indication for	
Supply ON	LED, green
Dupline® carrier	LED, yellow
Environment	
Operating temperature	-20° to +50°C (-4° to +122°F)
Storage temperature	-50° to +85°C (-58° to +185°F)
Humidity (non-condensing)	20 - 80%
Mechanical resistance	
Shock	15 G (11 ms)
Vibration	2 G (6 to 55 Hz)
Dimensions	Open PCB 54 x 40 mm 4 pcs. of nylon PA6 snap locks are included for mounting the PCB in ø 4.8 holes
Weight	50 g

Wiring Diagram

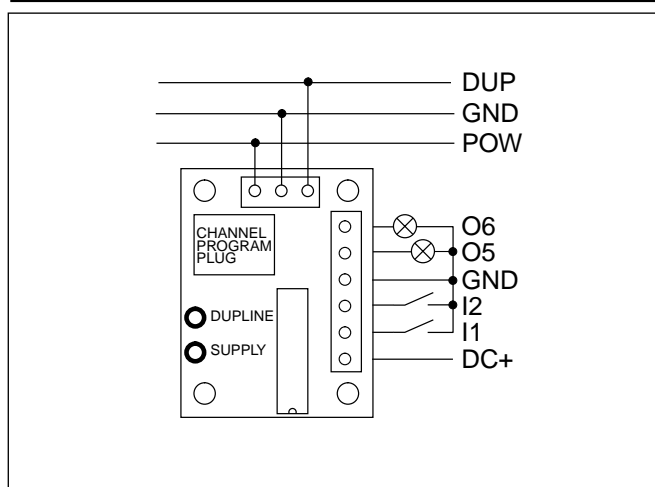

Pin Allocation

Terminal	Input/Output
DUP	Dupline® signal
GND	Dupline® + supply GND
POW	Supply IN
DC +	DC out
I 1	Input 1
I 2	Input 2
O 5	Output 1
O 6	Output 2

Programming Information

The table below shows the relation between the inputs/outputs of the G 2140 4421 and the In/Out-markings on the GAP1605.

GAP 1605	G 2140 4421
In/out 1	Input 1 (I1)
In/out 2	Input 2 (I2)
In/out 3	Not used
In/out 4	Not used
In/out 5	Output 1 (O5)
In/out 6	Output 2 (O6)
In/out 7	Not used
In/out 8	Not used

Mode of Operation

The I/O-units use three wires for the communication with all the other I/O-units of an installation, for the supply of the I/O-units and for the loads connected to the outputs of the units. This implies, that the “common” of the communication signal is identical to the “minus” of the supply.

The DC-supply voltage must connect to the system through a G 2196 0000 700, which also performs the chan-

nel generator function and the RS485 communication link to the elevator controller (please refer to the data sheet for G 21960 000 700 for details)

Each I/O-unit has 2 inputs (NPN/contact) and 2 PNP-outputs. Every input and output is given its individual address with the coding unit GAP 1605 (please refer to the respective data sheet for details). The ON/OFF-signal that is applied to the input of an I/O-unit is associated

to the address given to that input. Any output of an I/O-unit that is given the identical address will now follow that input signal and switch its output signal ON or OFF. This means that a signal which is input at one location (for example as an output from the lift controller) may be output wherever required and as many times as required.

An input pulse stretcher is used on every input to

assure that the changes of input signals (even extremely short ones) are communicated by the system.

The output status of all outputs of an I/O-unit may be pre-defined for cases like loss of power and loss of communication. Please refer to the paragraph “Output status setting” of the data sheet for the GAP 1605 to change the default setting (all outputs OFF).