

Conductive Sensors

2 to 4-point level controller

Type CL with teach-in

CARLO GAVAZZI

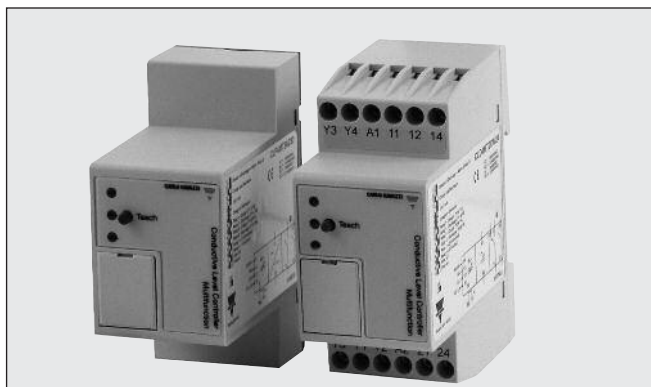

- Conductive level controller
- Teach-in of sensitivity – operating resistance from 220Ω to 220KΩ
- Multiple combinations of filling and emptying applications
- Low-voltage AC electrodes
- Easy installation on DIN rails or with 11 pin circular plug
- Rated operational voltage: 24 VAC/DC, 115 VAC or 230 VAC
- Output 2x8A/250 VAC SPDT relay
- LED indication for: Calibration, faulty operation and relay status

Product Description

μ-Processor based level controller for liquids with a wide sensitivity range (like sewage water, chemicals, salt water etc.). The controller has a separate output for alarm indication in case of a tank running dry or if an overflow condition occurs. 8A SPDT/SPST relay output, NO/NC.

Ordering Key

CLD4MT2DM24

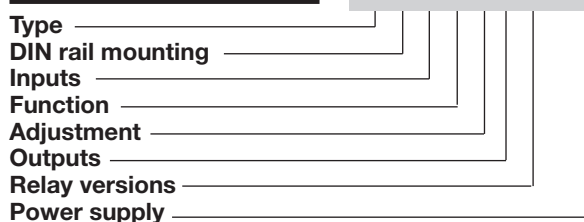

Type Selection

Mounting	Relay	Ordering no. Supply: 24 VAC/DC	Ordering no. Supply: 115 VAC	Ordering no. Supply: 230 VAC
DIN-rail	SPDT + SPST	CLD4MT2DM24	CLD4MT2D115	CLD4MT2D230
11-p circular plug	2 SPST	CLP4MT2AM24	CLP4MT2A115	CLP4MT2A230

Specifications

Rated operational voltage (U_B) Pin 2 & 10	230 115 24	195 to 265 VAC, 45 to 65 Hz 98 to 132 VAC, 45 to 65 Hz 19.2 to 28.8 VAC/DC <2.0 kVAC (rms)	Dielectric voltage	>2.0 kVAC (rms) (contacts / electronics)
Rated insulation voltage Rated impulse withstand voltage		4 kV (1.2/50 μs) (line/neutral)	Rated impulse withstand volt.	4 kV (1.2/50 μs) (contacts / electronics) (IEC 664)
Rated operational power AC supply AC/DC supply	5 VA 5 VA / 5 W		Operating frequency (f) Relay output	1 HZ
Delay on operate (t_v)	< 300 mS		Response time	1 s (3,5 s with filter)
Outputs Rated insulation voltage		Make or break on DIP-switch 250 VAC (rms) (cont./elec.)	Environment Overvoltage category Degree of protection Pollution degree	III (IEC 60664) IP 20 /IEC 60529, 60947-1) 2 (IEC 60664/60664A, 60947-1)
Relay Rating (AgCdO) Resistive loads	AC1 DC1 or AC11 DC13	μ (micro gap) 8 A / 250 VAC (2500 VA) 1 A / 250 VDC (250 W) 10 A 25 VDC (250 W)	Temperature Operating Storage	-20° to +50°C (-4° to + 122°F) -50° to +85°C (-58° to +185°F)
Small induc. Loads		0,4 A / 250 VAC 0,4 A / 30 VDC	Housing material	NORYL SE1, light grey
Mechanical life (typical)		≥ 30 x 10 ⁶ operations @ 18'000 imp/h	Weight AC supply AC/DC supply	200 g 125 g
Electrical life (typical)	AC1	> 250'000 operations	Approvals	UL508, cULus
Level probe supply		Max. 12 VAC	CE marking	Yes
Level probe current		Max. 2.5 mA		
Sensitivity		220Ω to 220KΩ Factory preset: 47KΩ		

Mode of Operation

Connection cable

2, 3, 4 or 5 conductor PVC cable, normally screened. Cable length: max. 100 m. The resistance between the cores and the ground must be at least 220k. Normally, it is recommended to use a screened cable between probe and controller, e.g. where the cable is placed in parallel to the load cables (mains). The screen has to be connected to Y5 (reference).

DIP-switch setting

Select the needed function on the DIP-switches, so that the desirable application occurs. Press the pushbutton in front of the controller shortly, until the green LED flashes once. The DIP-switch setting will now be read by the controller.

Teach-in:

Make sure that the reference electrode and one

of the other electrodes are in contact with the liquid – approximately 1 cm. Press the “teach” pushbutton at the front of the controller for approximately 2 seconds, until the green LED turns OFF. The controller will now auto-adjust itself according to the resistance of the measuring liquid. If the resistance of the liquid is outside the maximum range handled by the controller, the green LED will flash quickly for a period of 2 seconds, indicating a wrong teach-in.

Filter

The signal delay is selectable from 1 second or 3 seconds, and works for the on/off switching of the output relays.

Example 1

The diagram shows the level control connected as max.

and min. control, i.e. registration of 2 levels + 2 alarm levels. The relays react to the low alternating current created when the electrodes are in contact with the liquid.

The reference (Ref) must be connected to the container or if the container consists of a non-conductive material,

to an additional electrode. (To be connected to pin Y5). In the diagram this electrode is shown by the dotted line.) The alarm outputs utilize electrodes on Y1 for HiHi alarm and Y4 for LoLo alarm.

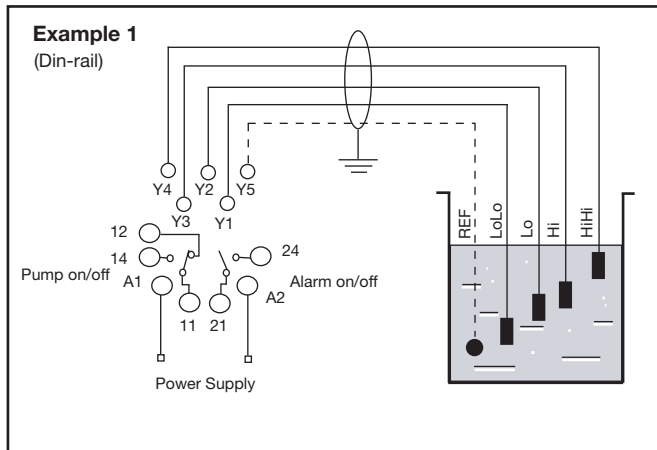

Function: Charge or Discharge

The Multifunction Controller can be used as a minimum-maximum control for up to two individual systems, with the same kind of liquid to be measured.

- ON
 DIP switches (Plug-version)
- 1 Function selection
 - 2 Function selection
 - 3 Relay 1 - Charge (off) or Discharge (on)
 - 4 Relay 2 - Charge (off) or Discharge (on)
 - 5 NO/NC
 - 6 Filter on/off
- ON

X-REFERENCE	
TERM	PLUG
Y1	8
Y2	6
Y3	5
Y4	4
Y5	7
A1	2
A2	10
11	1
12	-
14	3
21	11
24	9

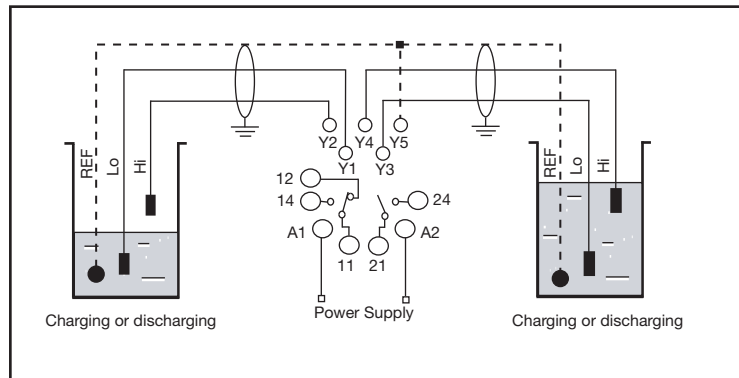

Charging

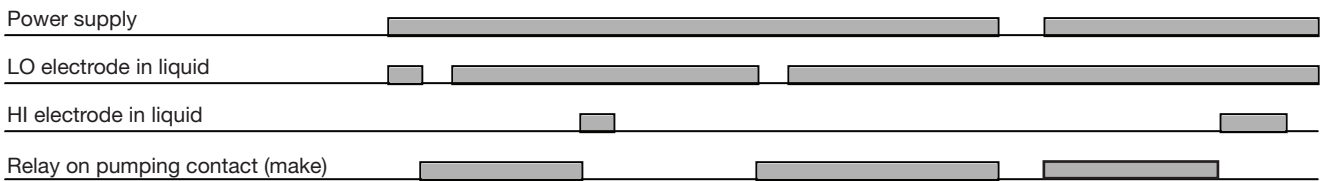

Discharging

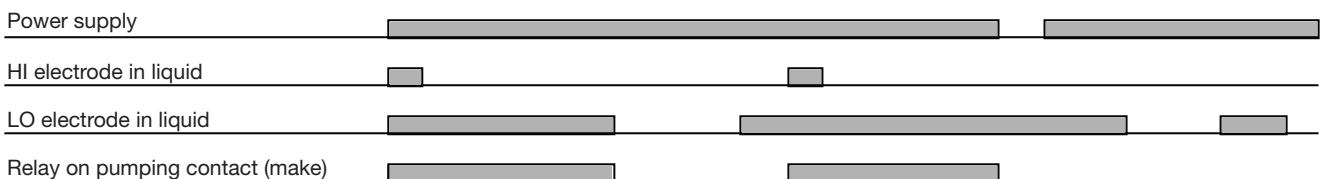

Operation Diagram

Function: Charge and Discharge

The Multifunction Controller can be used as a minimum-maximum control for two systems, a charging system and a discharging system, with the same kind of liquid to be measured and one common pump.

- ON
 DIP switches (Plu)
- 1 Function selection
 - 2 Function selection
 - 3 No function
 - 4 No function
 - 5 NO/NC
 - 6 Filter on/off
- ON

X-REFERENCE	
TERM	PLUG
Y1	8
Y2	6
Y3	5
Y4	4
Y5	7
A1	2
A2	10
11	1
12	-
14	3
21	11
24	9

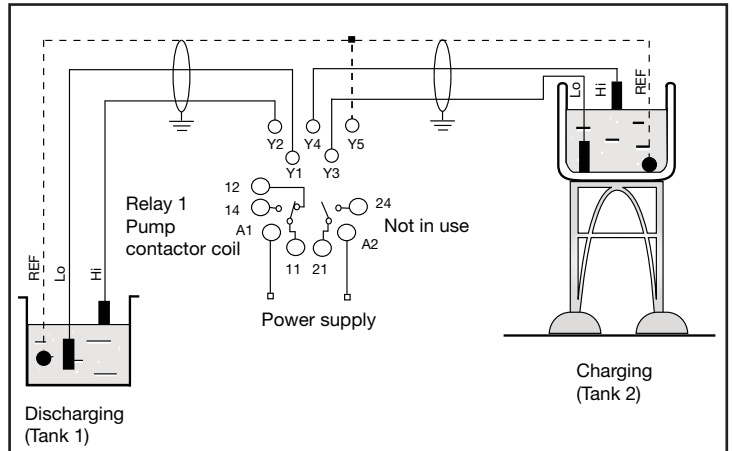

Charging and discharging

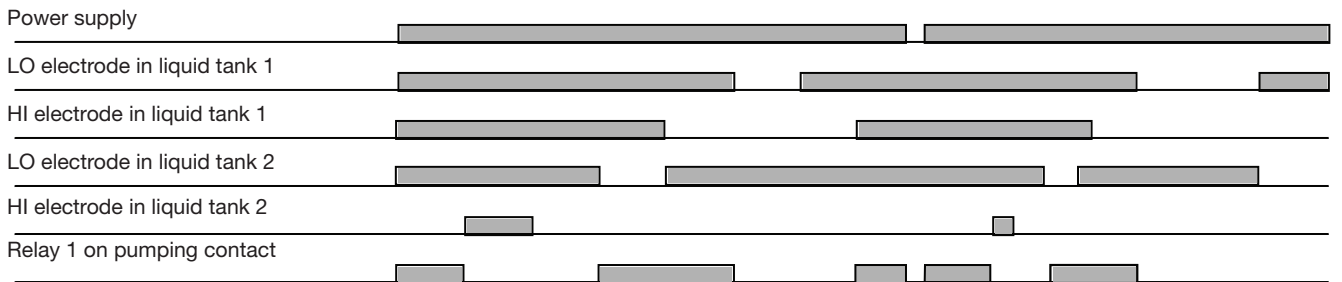

Function: Charge or Discharge with high and low alarms

The Multifunction Controller can be used as a minimum-maximum control charging or discharging system, with HiHi and LoLo Alarm output.

- ON
 DIP switches (Plug-version)
- 1 Function selection
 - 2 Function selection
 - 3 Relay 1 - Charge (off) or Disc
 - 4 Relay 2
 - 5 NO/NC
 - 6 Filter on/off
- ON

X-REFERENCE	
TERM	PLUG
Y1	8
Y2	6
Y3	5
Y4	4
Y5	7
A1	2
A2	10
11	1
12	-
14	3
21	11
24	9

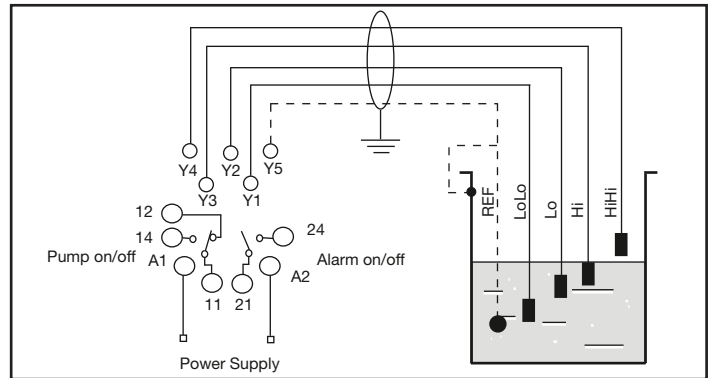

Charging

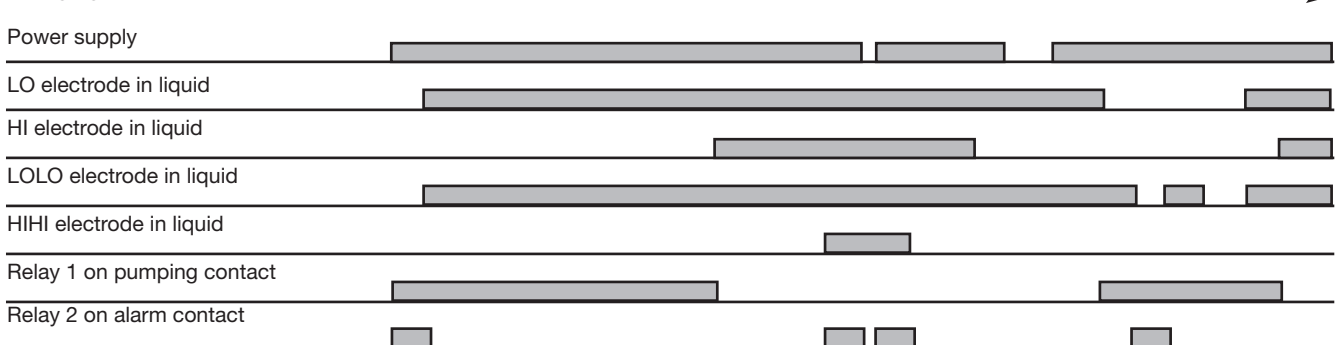

Operation Diagram

Function: Charge or discharge with low alarm

The Multifunction Controller can be used as a minimum-maximum control charging or discharging system, with one LoLo alarm output.

- ON
 ON
- DIP switches (Plug-version)
- 1 Function selection
 - 2 Function selection
 - 3 Relay 1 - Low alarm
 - 4 Relay 2 - Charge (off) or Disc
 - 5 NO/NC
 - 6 Filter on/off

X-REFERENCE	
TERM	PLUG
Y1	8
Y2	6
Y3	5
Y4	4
Y5	7
A1	2
A2	10
11	1
12	-
14	3
21	11
24	9

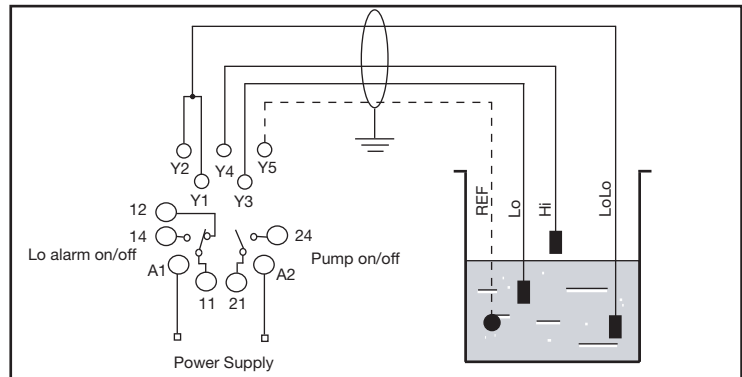

Function: Charge or discharge with high alarm

The Multifunction Controller can be used as a minimum-maximum control charging or discharging system, with one HiHi alarm output.

- ON
 ON
- DIP switches (Plug-version)
- 1 Function selection
 - 2 Function selection
 - 3 Relay 1 - Charge (off) or Disc
 - 4 Relay 2 - High alarm
 - 5 NO/NC
 - 6 Filter on/off

X-REFERENCE	
TERM	PLUG
Y1	8
Y2	6
Y3	5
Y4	4
Y5	7
A1	2
A2	10
11	1
12	-
14	3
21	11
24	9

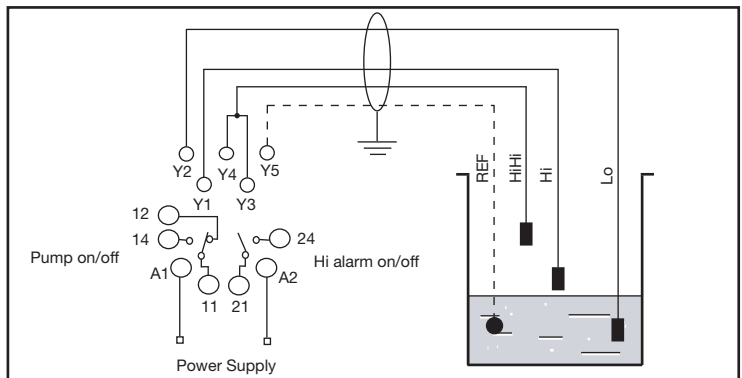

Function: Direct input- output

The Multifunction Controller can be used as direct input/ output, where each of the two inputs (electrodes) controls an individual relay output: Electrode no. 1 = Relay no. 1 Electrode no. 2 = Relay no. 2.

- ON
 ON
- DIP switches (Pl)
- 1 Function selection
 - 2 Function selection
 - 3 No function
 - 4 No function
 - 5 NO/NC
 - 6 Filter on/off

X-REFERENCE	
TERM	PLUG
Y1	8
Y2	6
Y3	5
Y4	4
Y5	7
A1	2
A2	10
11	1
12	-
14	3
21	11
24	9

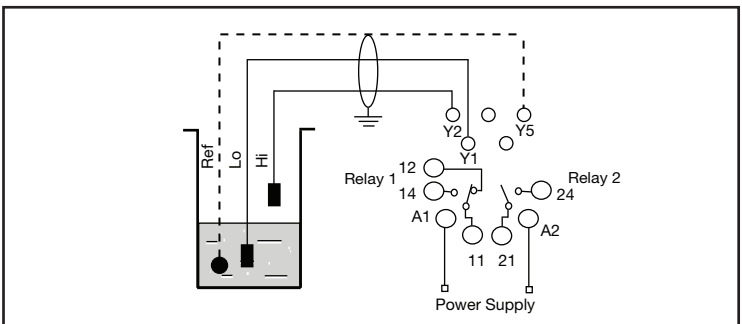



Direct input- output

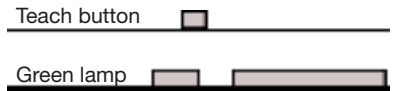

Operating Schedule

The following schedule provides an overview of the setup and failure situations

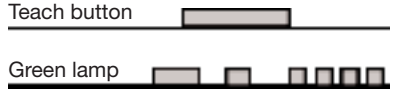
Situation	Condition	Action	Green Control lamp
Read DIP-switch setting	The DIP-switch setting has to match one of the descriptions written in "mode of operation"	Press the Teach-button in front of the controller shortly until the green control lamp turns off. Release the teach button immediately	
Teach-in	Fill the tank with the liquid to be measured until the second longest electrode is immersed approx. 1cm	Press the Teach button in front of the controller for approx. 2 seconds until the green control lamp turn off continuously. Release the teach button	
Failure indication	The Green lamp is flashing fast for approx 2 seconds after a teach-in operation	Control the electrode for short-cut connections. Control that the resistance of the measured liquid is within the specified range	

Wiring Diagram

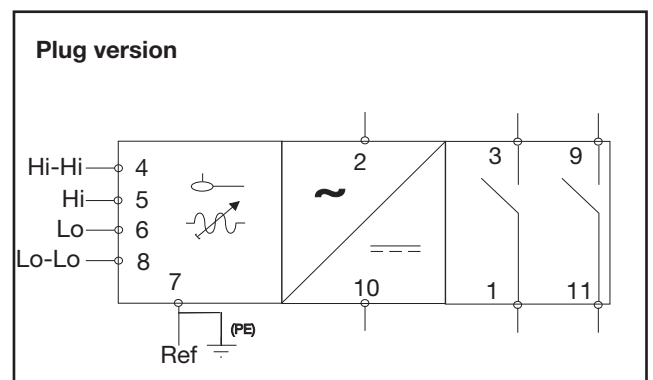
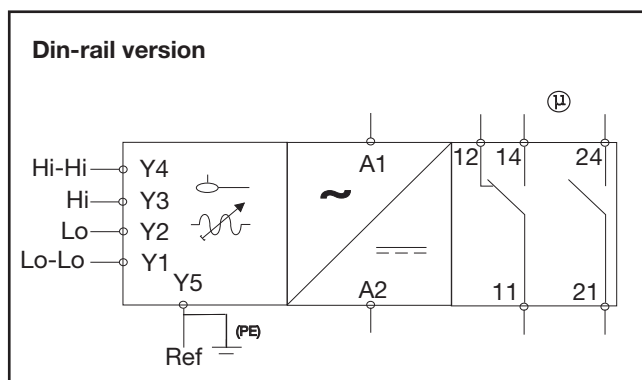

Dip Switch Settings

Din-rail version

ON ←

1 Charge or Discharge + Alarm (Relay 2)
 2 Charge and Discharge
 1 2 in 2 out
 2 Charge or Discharge
 3 Relay 1 - Charge (Y1 & Y2)
 3 Relay 1 - Discharge (Y1 & Y2)
 4 Relay 2 - Charge (Y3 & Y4)
 4 Relay 2 - Discharge (Y3 & Y4)
 5 Relay 1 + 2 not inverted
 5 Relay 1 + 2 inverted
 6 Filter off
 6 Filter on

ON

Plug version

→ ON

1 Charge or Discharge + Alarm (Relay 2)
 2 Charge and Discharge
 1 2 in 2 out
 2 Charge or Discharge
 3 Relay 1 - Charge (8 & 6)
 3 Relay 1 - Discharge (8 & 6)
 4 Relay 2 - Charge (5 & 4)
 4 Relay 2 - Discharge (5 & 4)
 5 Relay 1 + 2 not inverted
 5 Relay 1 + 2 inverted
 6 Filter off
 6 Filter on

ON

Dip Switch Function

	Dip-switch						Functionality	Comments
	1	2	3	4	5	6		
Function settings	0	0					Charge or discharge +alarm	One system in one tank
	1	0					Charge and discharge	One system in two tanks with one relay output
	0	1					2 in - 2 out	Each input direct controlling one output relay
	1	1					Charge or discharge	2 separate systems
Relay #1 function	1	1	0				Discharge	Emptying system #1
	1	1	1				Charge	Filling system #1
Relay #2 function	1	1	-	0			Discharge	Emptying system #2
	1	1	-	1			Charge	Filling system #2
Relay output	-	-	-	-	0		Normally open	Relays in normally open position
	-	-	-	-	1		Normally closed	Relays in normally closed position
Filter	-	-	-	-	-	0	Normal filter time	On-delay <0.5s
	-	-	-	-	-	1	Extended filter time	On-delay <2.0s

Dimension Drawings

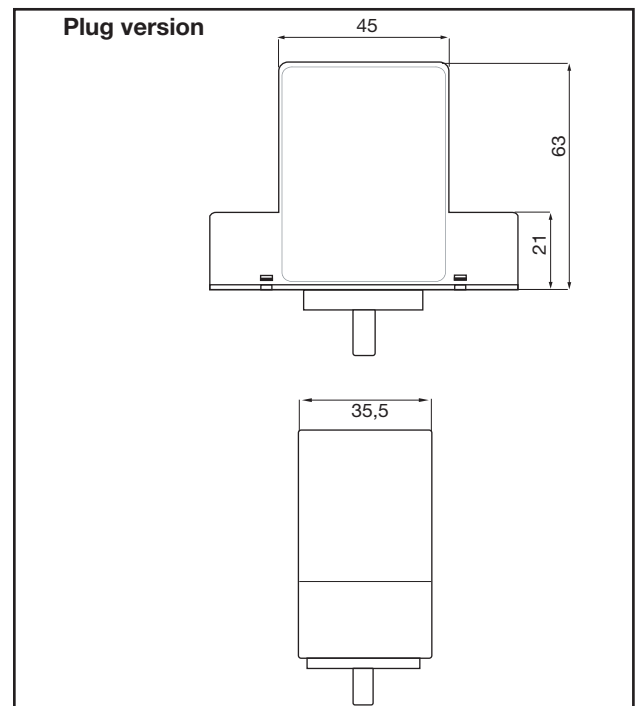
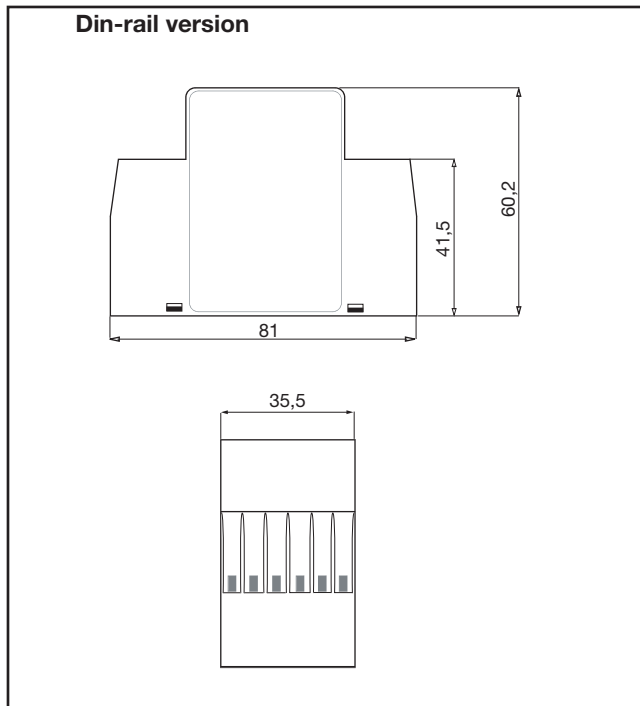

Accessories

- 11 pole circular socket ZVD11
- Mounting rack SM13

Delivery Contents

- Amplifier
- Packaging: Carton box
- Manual